

Thermodynamic Comparison of Linde and Claude Systems for Liquefaction of Gases

Devender Kumar^{*}, R. S. Mishra

Department Of Mechanical Engineering, Delhi Technological University, Shahabad, Delhi, India

Article Info

Article history:

Received 2 January 2014

Received in revised form

29 January 2014

Accepted 20 February 2014

Available online 15 March 2014

Keywords

Energy and Exergy analysis,
First and Second law efficiency,
Cryogenic Liquefaction masses

Abstract

The study deal with energy exergy comparative analysis of two cryogenics systems (i.e Linde Hampson and Claude) in terms of second law efficiency and the output (which in form of liquefaction mass) of gases, The numerical computation was carried out for above systems and it was conclude that by joining extra accessories in system make a system efficient in output result but in other hand making system large , its cost and as well as useful energy destruction of overall system are degraded which seen in from of low second law efficiency. Two system giving same atmospheric input condition and varying compressor pressure considered. Final results show the output of Claude system is more than the Linde system while seconde efficiency of of Linde system is 18 % more than the Claude system at 300 bar compressor pressure for all gases.

Nomenclature

W=work

Q=Heat input

η_I =First law efficiency

η_{II} =Second law efficiency

h=Enthalpy

s=Entropy

X=Dryness fraction

T=temperature

P=Pressure

m=mass

ϵ =Effectiveness of heat exchanger (approx. 80%)

η_{comp} =Efficiency of compressor (approx. 80%)

$\eta_{expander}$ =Efficiency of expander (approx. 80%)

C=Specific heat capacity fluid or gas

W_t =Work of reversible isothermal compression

W_{comp} =Shaft work supplied to compressor per unit mass

1. Introduction

Cryogenics is a field of acquiring very low temperature, the temperature which sufficient to liquefy most of gaes but generally the temperature below -150°C is considered in range of cryogenics. In early centuries the throttling effect of cooling and

various expansion device attract the scientist toward achieving low temperature but oxygen use in medical science and it storage factor turn 18 centuries scientist to attain low temperature which can liquefy air and in turn harness the oxygen from that liquefaction. In end of 18 centuries various research are done cryogenics field but first scientist which got success is Linde and after that lots of scientist liquefy various gas on their scale. Various system of cryogenics come in light in which Linde and Claude is widely used as system for liquefaction of air.

The system is made but how much they are efficient in industrial point of view is become matter of concern. Various method are employs to minimize the cost without affecting the production rate are investigated in various mathematical techniques and simulation technique is widely used. In all this a best method second law exergy analysis of system which is based on the second law of newton of energy destruction.

Exergy analysis is basically defined as the how much part of energy we can fully utilize in our work. Useful part of energy is called exergy while unused part is anergy. First law efficiency simply defined as the ratio of output to the input of energy while Second law efficiency deal with the exergy and defined as the ration of exergy output to the exergy input.

$$\eta_i = \frac{\text{Output energy}(W)}{\text{Input energy}(Q)}$$

Corresponding Author,

E-mail address: devenderdahiya@in.com

All rights reserved: <http://www.ijari.org>

$$\eta_{II} = \frac{\text{Exergy output}}{\text{Exergy Input}}$$

Lots of research are done to optimize and to increase the second law efficiency of system. And for this lots of new techniques are experimentally studied. Yang et al. [1] performed a comparative study on the trans critical carbon dioxide refrigeration cycles with a throttling valve and with an expander, based on the first and second laws of thermodynamics. Ignacio L'opezPaniagua [2] find New Simple Method for Estimating Exergy Destruction in Heat Exchangers. Yongliang Li [3] study An optimal design methodology for large-scale gas liquefaction. Antungalovic [4] do detail Analysis of Exergy Destruction of an

Evaporator or/and a Condenser. The main cause of low Second law efficiency directly link to the irreversibility of system so for which is just a form of exergy losses in any system. Irreversibility is the reason why the exergy received by the cold fluid and that released by the hot fluid are not equal. In fact, the total exergy loss in an exchanger is another characteristic of its exergetic behavior commonly referred to in the literature [5,6],and only part of the exergy loss can be avoided in practice [7]

2. Thermal analysis of Linde system

Linde system is first system which is use for liquefaction of air. In Fig 1(a).This system consist a compressor, heat exchanger, throttle valve and a separator. The air or gas which is used to liquefy is circulate in this closed cycle with perfect insulation to avoid large losses to occur due to system and outer surrounding temperature difference. Fig 1(b) show the temperature entropy diagram for Linde system.

$$\eta_{comp} = \frac{W_t}{W_{comp}} \tag{1}$$

$$W_t = mRT \ln \frac{P_2}{P_1} \tag{2}$$

$$W_{comp} = h_2 - h_1 - T_1 (s_2 - s_1) \tag{3}$$

$$W_{reversible} = W_{actual} - T_0 s_{gen} \tag{4}$$

$$W_{actual} = \frac{W_{comp}}{x} \tag{5}$$

$$W_{reversible} = h_5 - h_1 - T_0 (s_5 - s_1) \tag{6}$$

Heat Exchanger

$$m_2(h_2 - h_3) = m_6(h_1 - h_6) \tag{7}$$

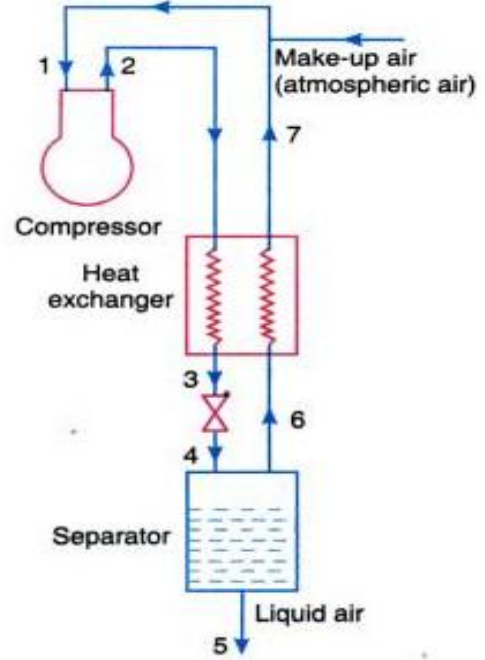

Fig: 1(a). Linde system for Liquefaction for gases

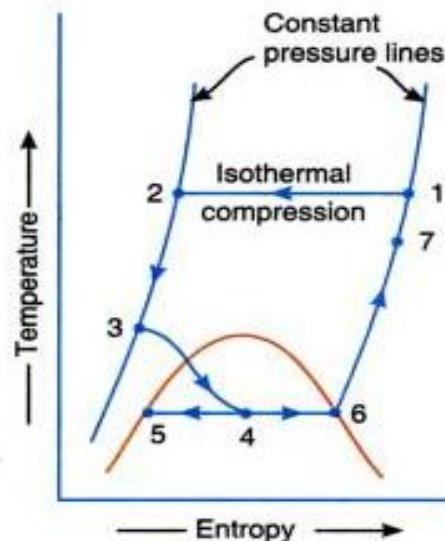

Fig: 1 (b). Tempertaure vs entropy of Linde system

$$m_2(h_2 - h_3) = (m_2 - m_5)(h_1 - h_6) \tag{8}$$

$$: m_6 = (m_2 - m_5) \tag{9}$$

$$\varepsilon = \frac{C_h (T_2 - T_3)}{C_{min} (T_2 - T_6)} \quad (10)$$

Throttling process:

$$h_3 = h_4 \quad (11)$$

Heat Balance of the separator

$$m_2 h_4 = m_5 h_5 + m_6 h_6 = m_5 h_5 + (m_2 - m_5)(h_6) \quad (12)$$

Second law analysis :

$$\eta_{II} = \frac{W_{rev}}{W_{actual}} \quad (13)$$

COP (coefficient of performance):

$$COP = \frac{h_2 - h_1}{h_2 - h_1 - T_1 (s_2 - s_1)} \quad (14)$$

2.2 Thermal analysis of Claude system

Claude system not only used for liquefaction of air but other gas also can be liquefy with this system also .Fig 2(a) show a block diagram of Claude system having two heat exchanger ,two separator and two throttle valve with an expander. Fig 2 (b) shows temperature entropy diagram.

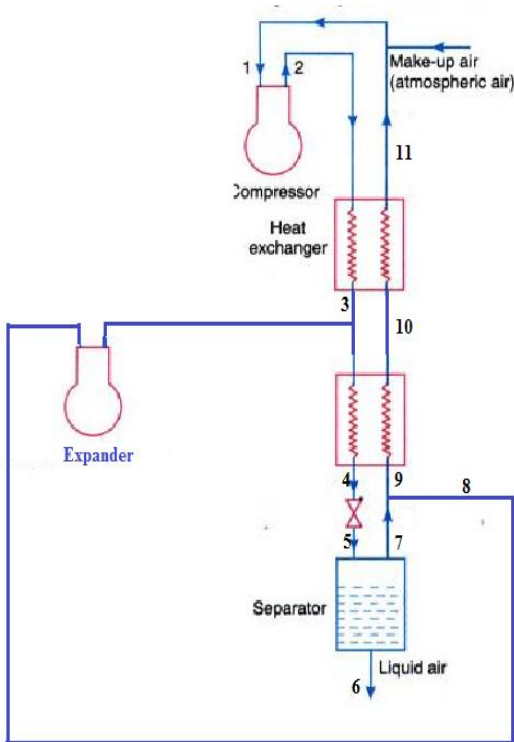

Fig: 2(a). Claude system for Liquefaction for gases

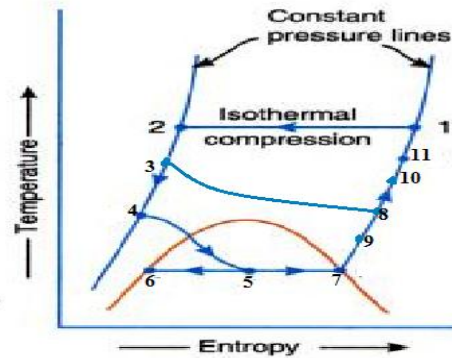

Fig: 2(b). Temperature vs entropy of Claude system

$$\eta_{comp} = \frac{W_t}{W_{comp}} \quad (15)$$

$$W_t = mRT \ln \frac{P_2}{P_1} \quad (16)$$

$$W_{comp} = h_2 - h_1 - T_1 (s_2 - s_1) \quad (17)$$

$$W_{reversible} = W_{actual} - T_0 S_{gen} \quad (18)$$

$$W_{Total} = W_{comp} + W_{Expander} \quad (19)$$

First heat exchanger:

$$m_2 (h_2 - h_3) = (m_2 - m_6) (h_1 - h_{10}) \quad (20)$$

Expander:

$$\frac{T_8}{T_3} = \left(\frac{P_8}{P_3}\right)^{\left(\frac{\gamma-1}{\gamma}\right) \eta_{expander}} \quad (21)$$

$$W_{Expander} = h_8 - h_3 \quad (22)$$

$$(m_4 - m_6 + m_8) h_9 = m_8 h_8 + (m_4 - m_6) (h_7) \quad (23)$$

Second Heat exchanger:

$$m_4 (h_3 - h_4) = (m_2 - m_6) (h_{10} - h_9) \quad (24)$$

Throttle valve:

$$h_4 = h_5 \quad (25)$$

Heat Balance of the separator

$$m_4 h_5 = m_6 h_6 + (m_4 - m_6) (h_7) \quad (26)$$

Second law analysis:

$$\eta_{II} (\%) = m_6 \left(\frac{h_7 - h_6 - T_0 (s_7 - s_6)}{W_c} \right) \times 100 \quad (27)$$

COP (coefficient of performance):

$$COP = \frac{h_1 - h_7}{h_2 - h_1 - T_1 (s_2 - s_1)} \quad (28)$$

Table: 1. Performance parameters of Linde and Claude System for air

Linde System (Air)				ClaudeSystem (Air)			
COP	$\eta_{2^{nd}}$ law(%)	m_Liq mass	P (Comp Pre)	COP	$\eta_{2^{nd}}$ law(%)	m_Liq mass	P (Comp Pre)
0.5612	8.891	0.04751	100	0.4836	10.35	0.08203	200
0.487	12.64	0.0778	200	0.4471	11.12	0.09533	300
0.4501	13.58	0.09048	300	0.4225	10.58	0.09603	400
0.4253	12.92	0.0911	400	0.4036	9.383	0.08913	500
0.4063	11.43	0.08433	500				

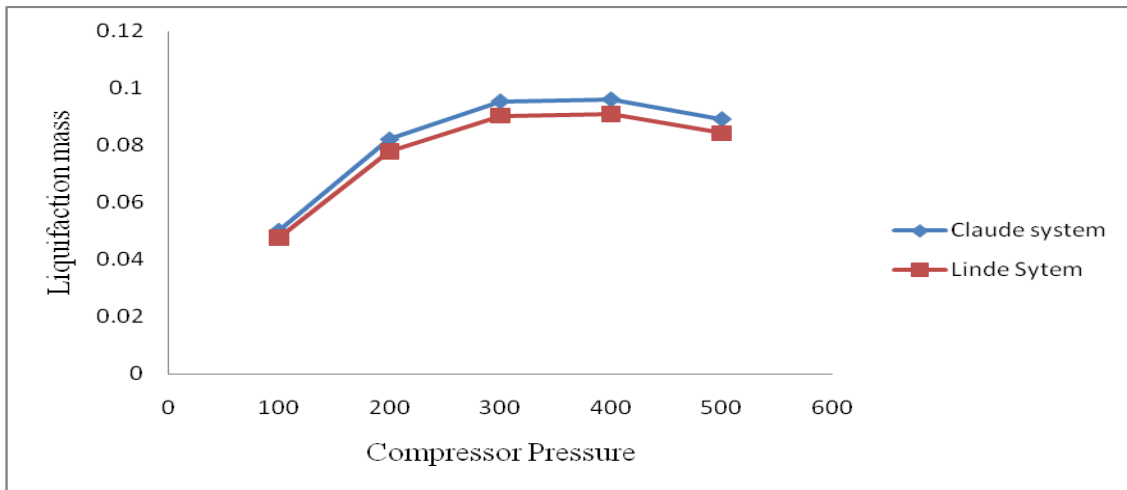

Fig: 3(a). Variation of Liquefaction mass with compressor pressure of air

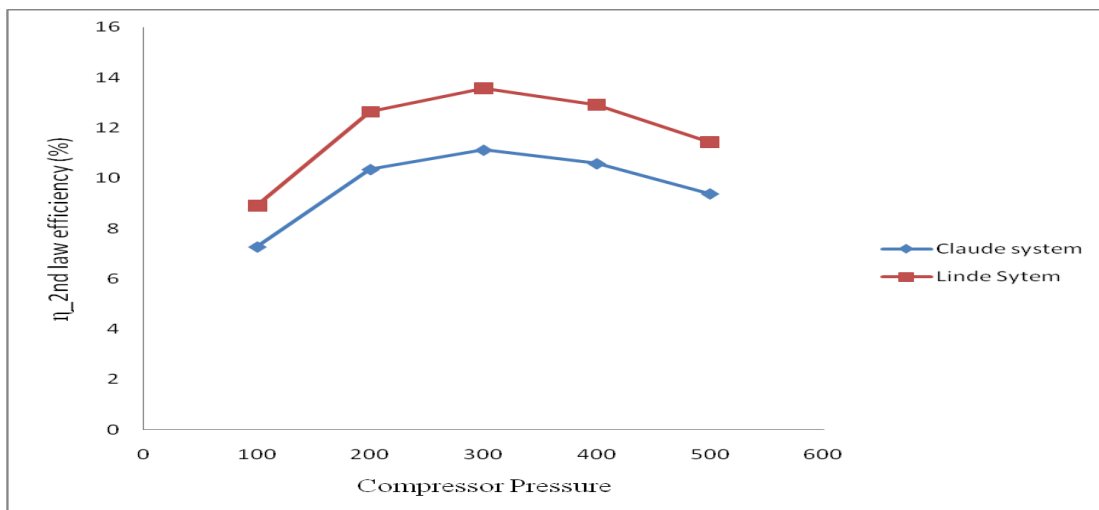

Fig: 3(b). Variation of Second law efficiency (%) with compressor pressure of air

Table: 2. Performance parameters of Linde and Claude System for Nitrogen

Claude System (N)				Linde System (N)			
COP	$\eta_{2^{nd}}$ law(%)	m_Liq mass	P (Comp Pre)	COP	$\eta_{2^{nd}}$ law(%)	m_Liq mass	P (Comp Pre)
0.5679	6.818	0.04781	100	0.5721	8.521	0.04539	100
0.4921	9.851	0.07971	200	0.4954	12.3	0.07564	200
0.4543	10.87	0.09531	300	0.4571	13.57	0.09048	300
0.4287	10.67	0.09914	400	0.4314	13.32	0.09408	400
0.4091	9.795	0.09534	500	0.4116	12.2	0.0903	500

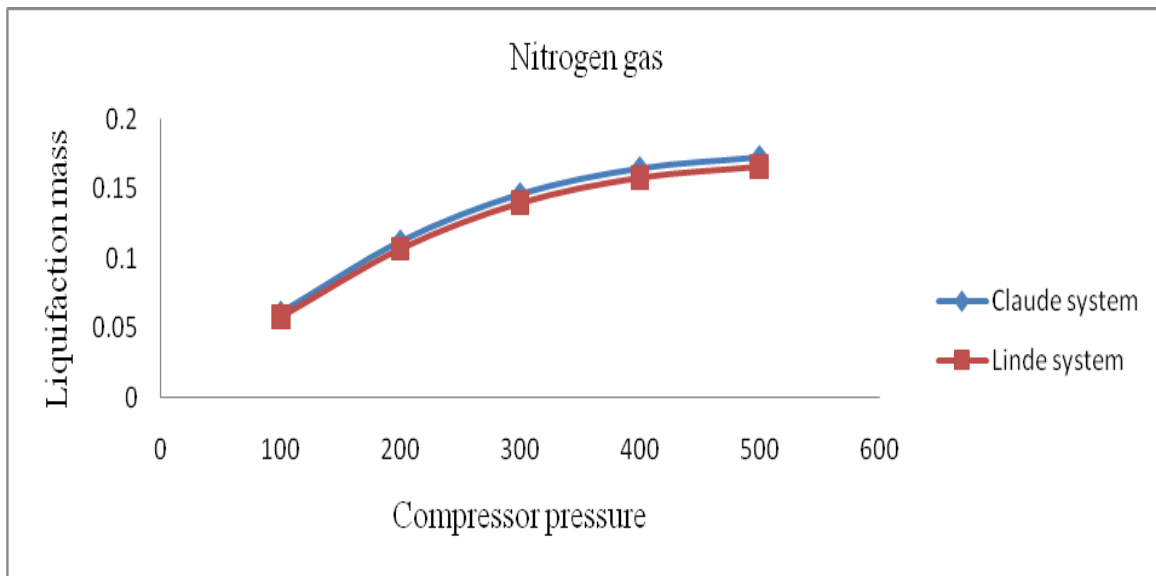

Fig: 3(c). Variation of Liquefaction mass with compressor pressure of nitrogen

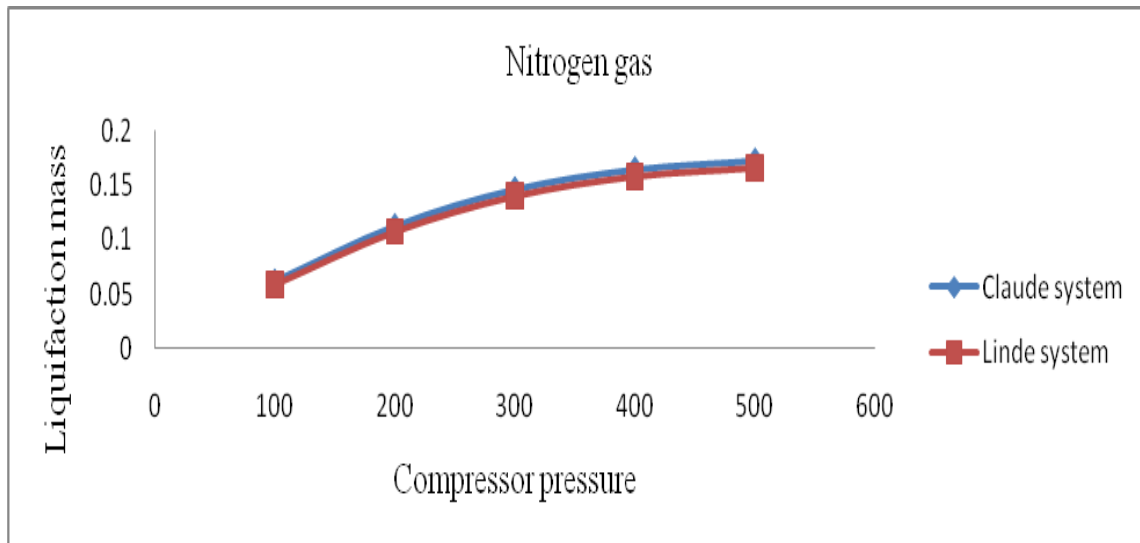

Fig: 3(d). Variation of Second law efficiency (%) with compressor pressure of nitrogen

Table: 3 Performance parameters of Linde and Claude System for Methane

ClaudeSystem (CH4)			
COP	$\eta_{2^{nd}}$ law(%)	m_Liq mass	P (Comp Pre)
0.5765	14.78	0.1164	100
0.5114	23.56	0.2091	200
0.4784	26.27	0.2492	300
0.4547	26.21	0.2615	400
0.4355	25.11	0.2617	500

LindeSystem (CH4)			
COP	$\eta_{2^{nd}}$ law(%)	m_Liq mass	P (Comp Pre)
0.5829	17.43	0.1105	100
0.5161	27.8	0.1991	200
0.4825	31.24	0.2392	300
0.4585	31.31	0.2523	400
0.4392	30.08	0.2531	500

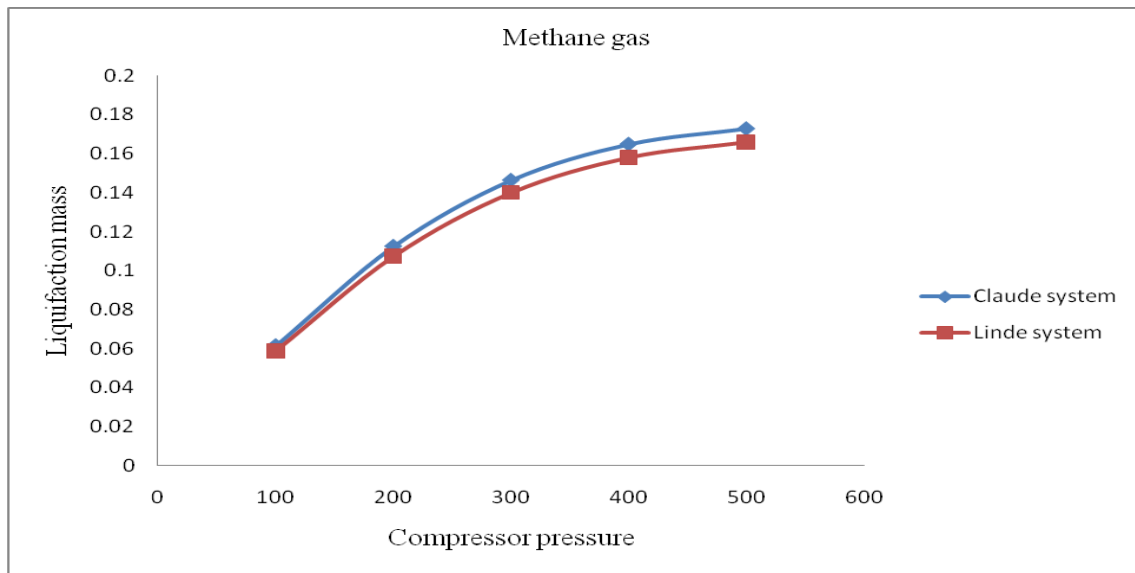

Fig: 3(e). Variation of Liquefaction mass with compressor pressure of methane

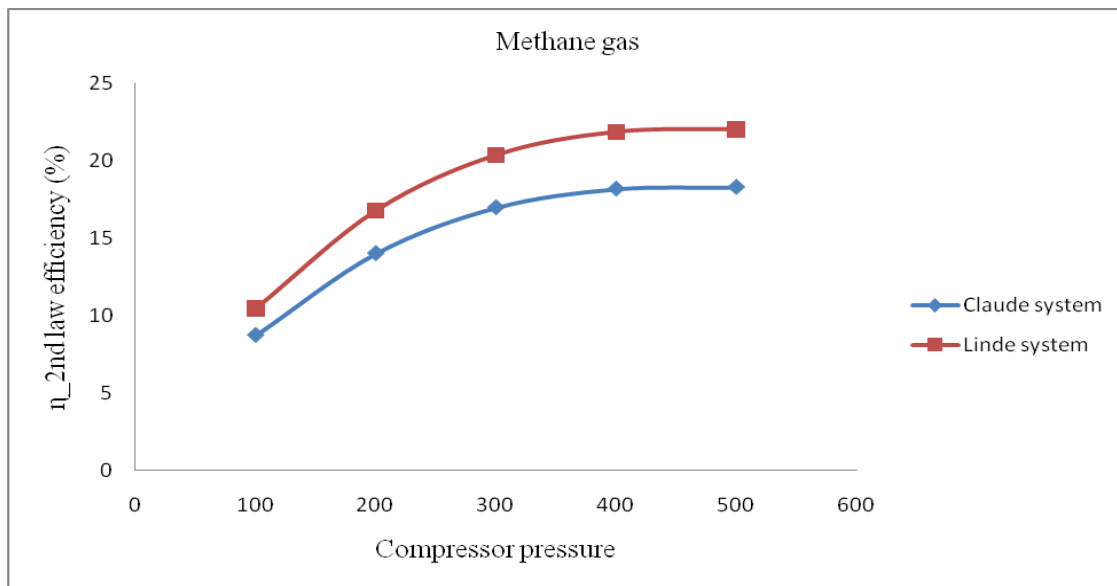

Fig: 3(f). Variation of Second law efficiency (%) with compressor pressure of methane

Table: 4. Performance parameters of Linde and Claude System for Flourine

ClaudeSystem (F)			
COP	$\eta_{2^{nd}}$ law(%)	m_Liq mass	P (Comp Pre)
0.5608	6.713	0.04466	100
0.489	10.57	0.08062	200
0.4541	13.01	0.1069	300
0.4311	14.22	0.123	400
0.4137	14.6	0.1316	500

LindeSystem (F)			
COP	$\eta_{2^{nd}}$ law(%)	m_Liq mass	P (Comp Pre)
0.5661	8.097	0.04266	100
0.4932	12.67	0.07665	200
0.4578	15.59	0.1016	300
0.4345	17.05	0.117	400
0.4169	17.52	0.1254	500

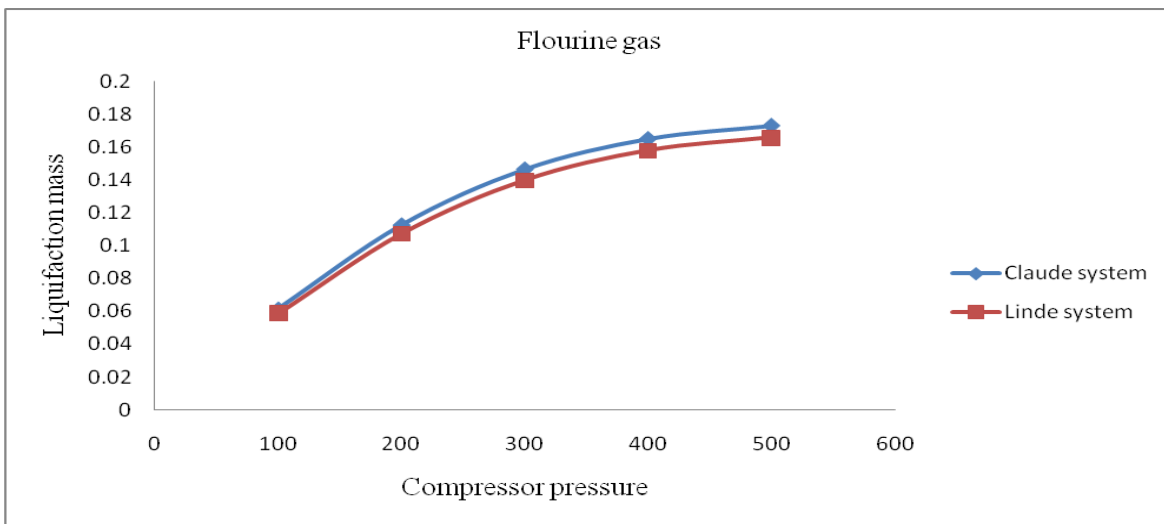

Fig: 3(g). Variation of Liquefaction mass with compressor pressure of Flourine

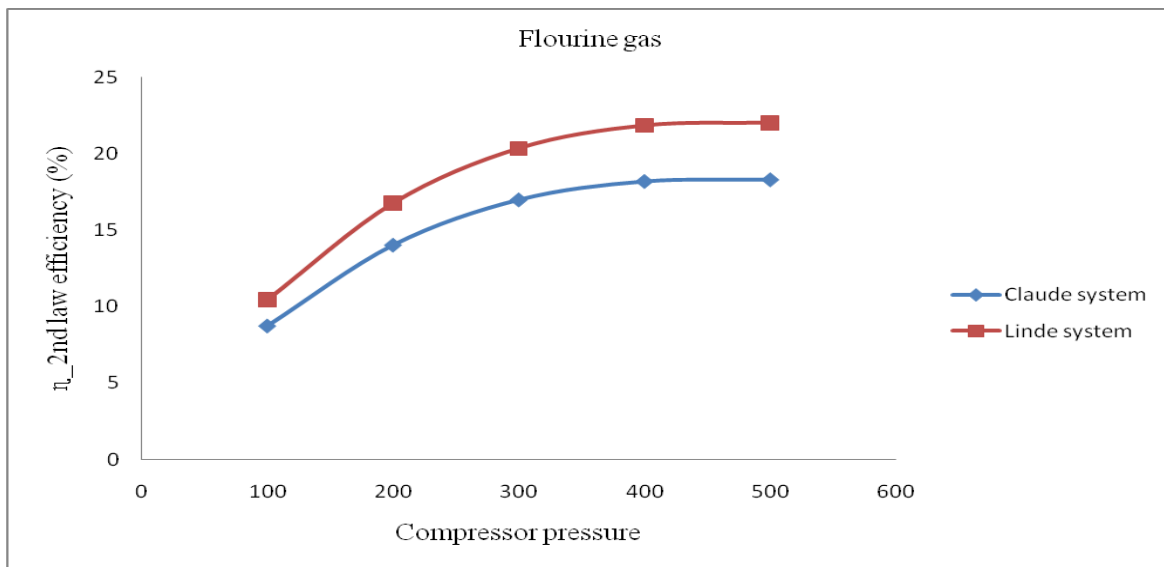

Fig: 3(h). Variation of Second law efficiency (%) with compressor pressure of Flourine

Table: 5. Performance parameters of Linde and Claude System for Argon

ClaudeSystem (Ar)				LindeSystem (Ar)			
COP	$\eta_{2^{nd}}$ law(%)	m_Liq mass	P (Comp Pre)	COP	$\eta_{2^{nd}}$ law(%)	m_Liq mass	P (Comp Pre)
0.3923	9.83	0.06649	100	0.3955	11.1	0.06352	100
0.343	15.62	0.1209	200	0.3454	17.61	0.1154	200
0.3191	18.82	0.1565	300	0.3212	21.24	0.1497	300
0.3032	20.07	0.1757	400	0.3051	22.7	0.1684	400
0.291	20.12	0.1835	500	0.2928	22.79	0.1761	500

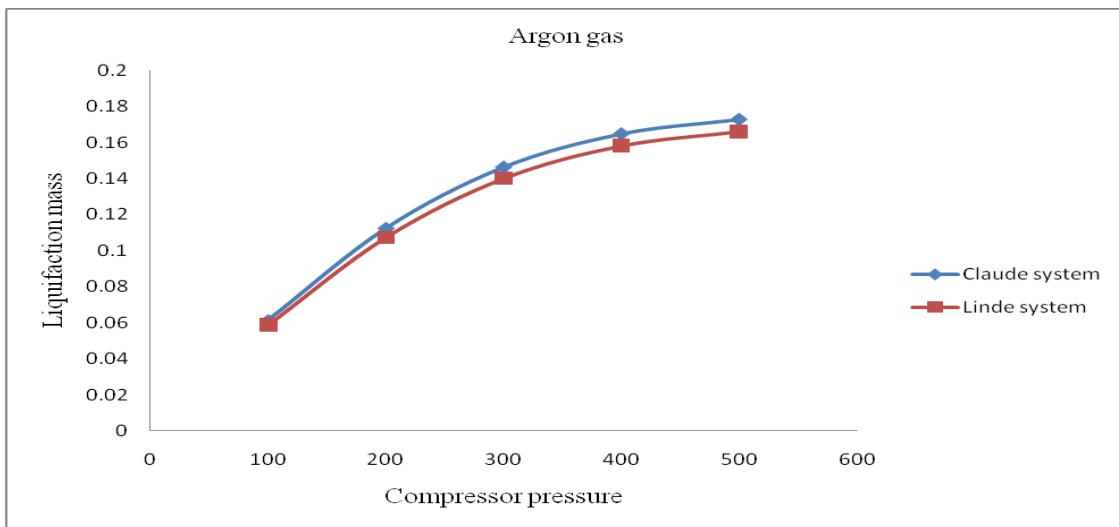

Fig: 3(i). Variation of Liquefaction mass with compressor pressure of Argon

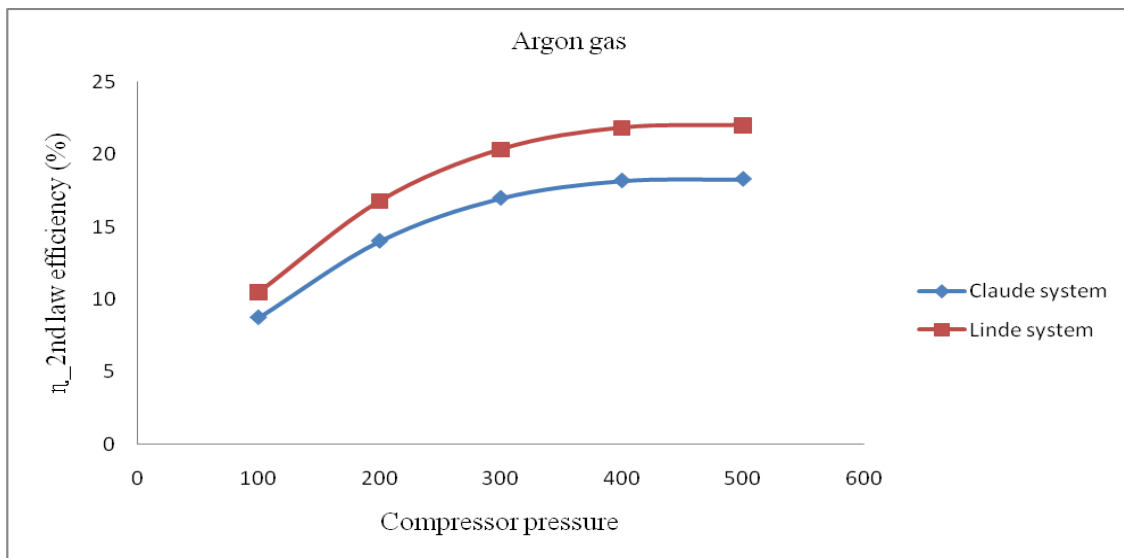

Fig: 3(j). Variation of Second law efficiency (%) with compressor pressure of Argon

Table: 6. Performance parameters of Linde and Claude System for Oxygen

ClaudeSystem (O2)			
COP	$\eta_{2^{nd}}$ law(%)	m_Liq mass	P (Comp Pre)
0.5395	8.732	0.06136	100
0.4719	14.01	0.1125	200
0.4392	16.97	0.1465	300
0.4174	18.17	0.165	400
0.4007	18.28	0.173	500

LindeSystem (O2)			
COP	$\eta_{2^{nd}}$ law(%)	m_Liq mass	P (Comp Pre)
0.5441	10.47	0.05851	100
0.4755	16.77	0.1072	200
0.4422	20.34	0.1399	300
0.4202	21.83	0.158	400
0.4033	22.01	0.1659	500

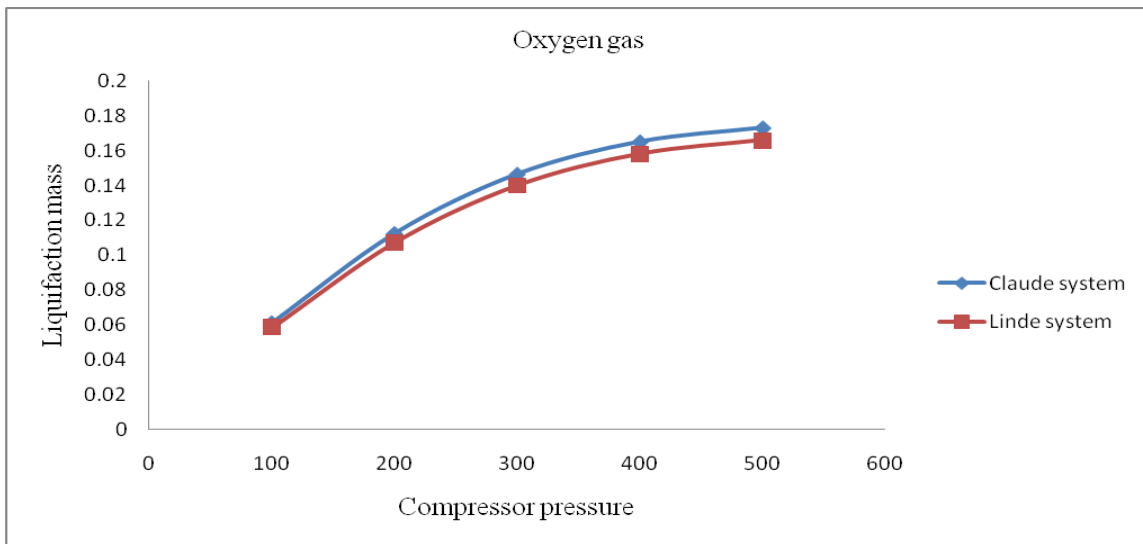

Fig: 3(k). Variation of Liquefaction mass with compressor pressure of Oxygen

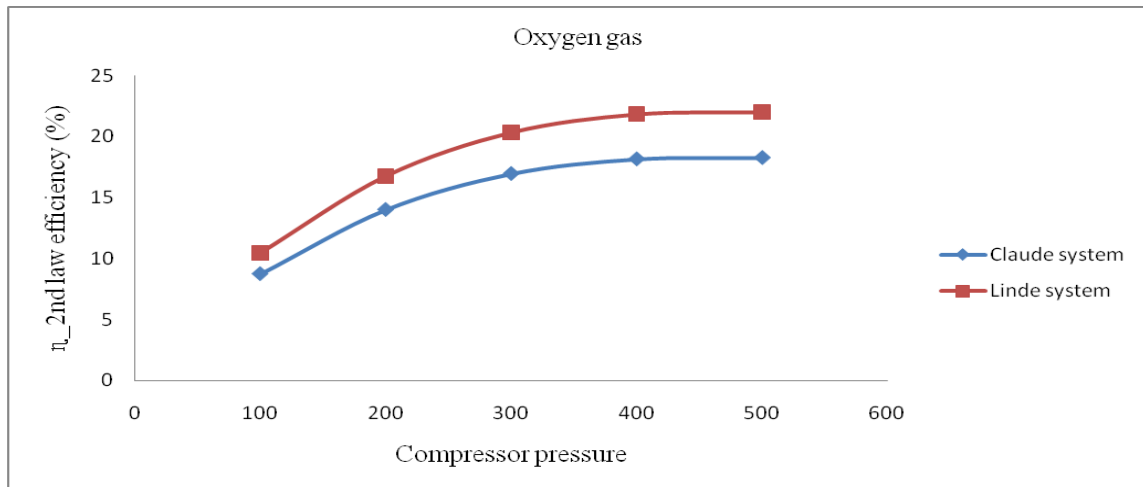

Fig: 3(l). Variation of Second law efficiency (%) with compressor pressure of Oxygen

3. Results and discussion

Using thermodynamic first and second law analysis, the comparison between Linde and Claude systems for liquefaction of gases have been made for constant inlet condition and performance parameters were evaluated are shown in table 1-6 respectively. Computational numerical technique is used for both system for varying compressor pressure and results are shown in Figs 3 respectively. It was observed that the liquefaction mass of gases is higher in Claude system as compared to Linde system, so output of Claude system is more than the Linde system. The compressor pressure is not directly proportional to liquefaction mass, liquefaction mass is higher in range of 300 to 400 bar compressor pressure, further increase in pressure degrade the quantity of liquefaction mass in both system.

References

- [1] J. L. Yang, Y. T. Ma, M. X. Li, H. Q. Guan, "Exergy analysis of transcritical carbon dioxide refrigeration cycle with an expander", *Energy* 30 (2005) ISSN 1162-1175.
- [2] Ignacio Lopez Paniagua, Javier Rodriguez Mart'in, Celina Gonzalez Fernandez, Angel Jimenez Alvaro, Rafael Nieto Carlier, "A new simple method for estimating exergy destruction in heat exchangers", *Entropy* (2013), 15, 474-489; ISSN 1099-4300
- [3] YongliangLi, Xiang Wang, Yulong Ding, "An optimal design methodology for large-scale gas liquefaction", *Applied Energy* 99 (2012) 484-490, ISSN 0306-2619
- [4] Antungalovic, Marijazivicand Matokokanovic, "Analysis of exergy destruction of an evaporator or/and a condenser", *Strojarstvo* 51(1) 73-78 (2009), ISSN 0562-1887
- [5] A. Franco, A. Russo, "Combined cycle plant efficiency increase based on the optimization of the heat recovery steam generator operating parameters", *Int. J. Therm. Sci.* 41 (2002), 843-859
- [6] R. Saidur, J. Ahamed, Masjuki, H. Energy, "Exergy and economic analysis of industrial boilers", *Energy Policy* 38 (2010), ISSN 2188-219
- [7] T. J. Kotas, "The Exergy Method of Thermal Plant Analysis", 1995 Ed.; Krieger Publishing Company: London, UK, 1985

Using exergy analysis it was observed that the second law efficiency of Linde system is more than the Claude system and compressor pressure in range of 300 to 330 bar show highest efficiency for all gases

4. Conclusion

1. Linde system having less energy losses than Claude system showing higher second law efficiency than Claude system for all gases mention above.
2. Output wise the Claude system is better than Linde system for all gases mention above.
3. Compressor pressure range 300 to 350 show good result in both system at constant slandered atmospheric inlet conditions