

# Transformation of Indian Power Transmission System

Himanshu Singh, Naresh Kumari\*

Department of Electrical, Electronics and Communication Engineering, The NorthCap University, Gurugram, Haryana, India

## Article Info:

Article history:

Received 25 July 2017

Received in revised form

20 August 2017

Accepted 28 August 2017

Available online 15 September 2017

## Keywords:

Transmission system, Power Sector, Open Access, SCADA

## Abstract

India is standing on threshold of becoming a superpower by the year 2030. A conclusive growth of a country takes into account all the major sectors involved in running its economy every day. One of the most important sector out of these is 'Power Sector'. All the three parts of power sector i.e. Generation, Transmission and distribution have gone a rapid transformation since independence and development of all the three sub-sectors is important to ensure overall growth of Indian power sector. Since the day government has introduced open access in power sector which has been termed as giant leap for our country's power sector, there has been a tremendous response from both sides (consumers as well as producers). After the creation of PGCIL in 1989 the growth of transmission has been manifold since the operations have been handed over by NTPC to PGCIL. It is notable to mention the achievement of PGCIL in transmission Sub-sector which has pioneered in this field and is running its operation in 10+ countries besides its pan-India operation, this alone is enough to prove the fast transformation Power sector has seen in recent years.

## 1. Introduction

Ever since India gained independence in the year 1947 it was a dream to achieve 100% electrification of all the villages and towns and most importantly become capable enough to generate and feed its people with required amount of power. From the below given table it is clearly evident that we have transformed into a country which has the ability to generate surplus power and offer it to our neighbouring country as well. Since electricity is a concurrent subject both centre as well as state government are responsible for development of power sector across India. Various central government controlled companies like NTPC, NHPC, THDC, NEEPCO, SJVNL as well as state government companies are operating and central transmission utility PGCIL is responsible for interconnecting various states and ensuring unification in the grid. A vast network of Transmission lines has been developed and an even greater number is in process of being developed in our country for extracting power produced by different electricity generators across the country and distribute the same to the consumers. On basis of the quantum of power required and the distance involved, lines of appropriate voltages as deemed necessary are laid. Extra High Voltage lines are  $\pm 800$  kV HVDC & 765 kV, 400 kV, 230/220 kV, 110 kV and 66 kV AC lines. All these lines have been laid down by state electricity board in consonance with the central utility. India's electricity generation in 1950-1985 was very low in comparison to those of developed nations. After 1990, India has been successful in recording faster growth in both electricity generation and its successful transmission. India's electricity generation which was just 179 TW-hr in 1985 rose to 1,057 TW-hr in 2012.

## 2. Transformation of Indian Transformation System

Private players were not allowed to be a party in the Indian power sector till 1991. But, in 1991 power generation sector allowed the participation of private players. The Electricity Regulatory Commission Act, 1998, made it compulsory for establishing an independent regulatory bodies both at the central and state levels.

Electricity Act, 2003, has further eased the approach for private players in Indian power sector. In transmission sector, projects are required to be marked for Tariff Based Competitive Bidding (TBCB). CERC and SERCs have authority to grant licenses for setting up, maintaining and operating transmission lines. In this, public utilities as well as private players are allowed to take part individually or as a joint venture.

The Indian Transmission Network was made after analysing new projects, upgrading existing lines and e.t.c. A high level committee would find the projects which are required to be developed and would award those projects after analysing participating bids. Central electricity authority has been tasked to monitor the progress

### \*Corresponding Author

E-mail address: nareshkumari@ncuindia.edu

All rights reserved: <http://www.ijari.org>

of all such projects awarded as per the guidelines that have been framed out. National Tariff Policy 2006 made Tariff Based Competitive Bidding (TBCB) compulsory specifically for all the transmission projects which are targeted to promote competition in procuring transmission services. It also encourages greater participation by private players in the transmission sector and increase transparency in the process of procurement so as to ensure availability of equal chances to all.

## 3. Open Access Rules and Regulations

The Electricity Act, enacted in the year 2003 vows to provide a transparent Open access in both transmission and distribution so as to promote fairness and competition in already accelerating power sector of our country. According to these rules and regulations consumers became so powerful so as to choose the supplier of electricity from whom they wish to purchase. Central Electricity Regulatory Commission (CERC) also made certain rules and regulations for STOA (Short Term Open Access). On similar lines, state electricity board also made their own arrangements to facilitate intra transmission in their respective states. The motive of government to introduce Open Access was to increase competition in the power sector, benefit to consumers and improve services.

STOA was successful since its launch and main reasons behind that are the extensive support and coordination shown by both central regulatory authority and state authority, transparency and fairness. The main responsibility for the development of India's Electricity Market has been bestowed upon Central Electricity Regulatory Commission. The CERC as per the Section 66 of the Electricity Act 2003 (EA 2003), Section 5.7 of the National Electricity Policy (NEP) mandates promotion of competition in the Electricity Sector so as to ensure maximum benefit to the end customer and maximise fairness in the entire process. The Central Electricity Regulatory Commission (CERC) is also responsible for ensuring the development of the electricity Market at the inter-state level.

## 4. SCADA /EMS System

With the magnitude of power transmission increasing manifold it has become increasingly important that the faults occurring along the transmission line should be addressed at the earliest. Until recently we were untouched by the modern advance protection system that are in place in different parts of world, but the recent introduction of SCADA and EMS have made us stand in line with countries having advance protection system in place which have the ability to detect the fault at its earliest. Subsequently the data and somewhat the cause of fault also can be detected by the operator sitting at a substation hundreds of kilometre away. The Indian grid which previously was divided into five grid namely - NR (Northern Region), WR (Western region), SR (Southern Region), ER (Eastern Region) and NER (North Eastern-Region). SCADA system is hierarchical in nature and it comprises of two distinct hierarchies - first one at the national level and the other one

at regional level. SCADA/EMS of all five RLDCs report to NLDC. Real time data is processed at RLDCs and NLDCs. Major SCADA functions includes data acquisition from RTUs and storage of data in online database. • Data processing to convert newly acquired values to engineering values. • Supervision of elements of any given network. • Storing data for future usage. • Reconstructing events in order to understand them and try to place necessary precautionary measure. • Informative tagging of power system device. • Load Management. • Sequential event recording. • Providing user interface to operators. • Providing communication with other control centres for data sharing and enhancing control over the whole power system network. • Real time generation function shows the operator real time generation figures and enables him to control the generation in real time. • Economic dispatch - It helps the operator to determine the economic base points for a selected set of units.

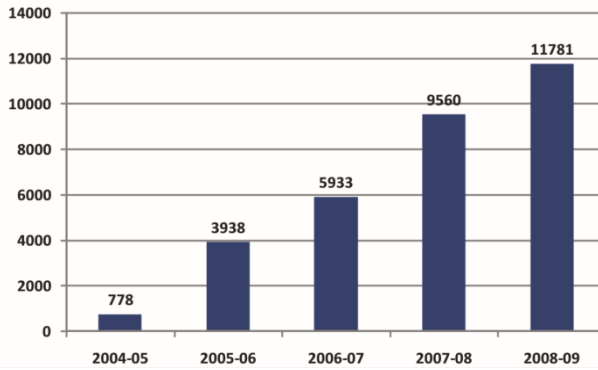

Fig. 1: Inter-State Short-term Open Access applications approved

Table 1: Installed Capacity over the Years

Installed Capacity as on	Thermal (MW)			Sub-Total Thermal (MW)	Nuclear (MW)	Renewable (MW)		Total (MW)	% Growth (on yearly basis)
	Coal	Gas	Diesel			Hydel	Other Renewable		
31-Dec-1947	756	-	98	854	-	508	-	1,362	-
31-Dec-1950	1,004	-	149	1,153	-	560	-	1,713	8.50%
31-Mar-1956	1,597	-	228	1,825	-	1,061	-	2,886	13.04%
31-Mar-1961	2,436	-	300	2,736	-	1,917	-	4,653	12.25%
31-Mar-1966	4,417	137	352	4,903	-	4,124	-	9,027	18.80%
31-Mar-1974	8,652	165	241	9,058	640	6,966	-	16,664	10.58%
31-Mar-1979	14,875	168	164	15,207	640	10,833	-	26,680	12.02%
31-Mar-1985	26,311	542	177	27,030	1,095	14,460	-	42,585	9.94%
31-Mar-1990	41,236	2,343	165	43,764	1,565	18,307	-	63,636	9.89%
31-Mar-1997	54,154	6,562	294	61,010	2,225	21,658	902	85,795	4.94%
31-Mar-2002	62,131	11,163	1,135	74,429	2,720	26,269	1,628	105,046	4.49%
31-Mar-2007	71,121	13,692	1,202	86,015	3,900	34,654	7,760	132,329	5.19%
31-Mar-2012	112,022	18,381	1,200	131,603	4,780	38,990	24,503	199,877	9.00%
31-Mar-2015	169,118	23,062	1,200	188,898	5,780	41,267	35,777	271,722	11.98%
31-Mar-2016	185,172	24,508	993	210,675	5,780	42,783	42,727	301,965	11.13%

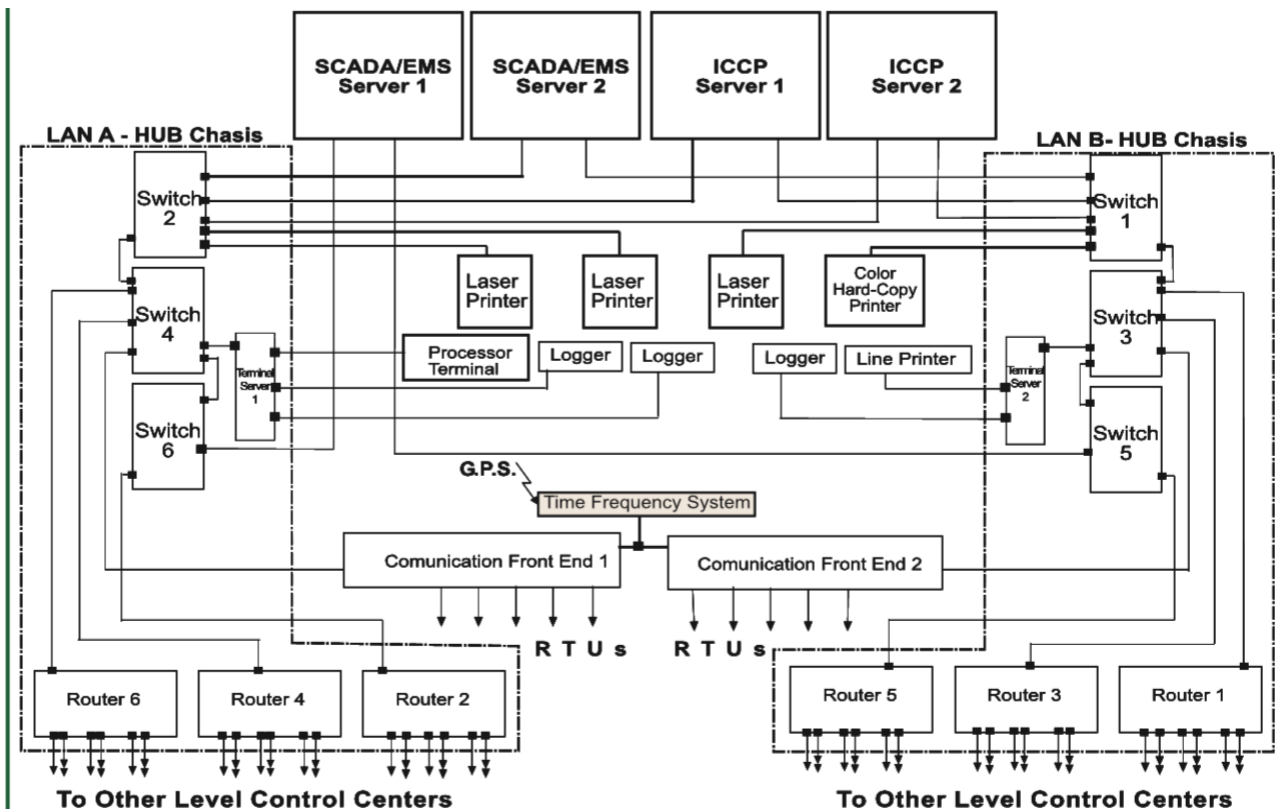

Fig. 2: SCADA system and modern control centers of transmission system

### 5. Conclusions

All throughout this report we have seen that how vast the Indian power system network is and the complexity it carries with it. But, recent advancements have given a big breather to the operators

controlling the network. Electric power is a big indicator of progress of a country and India envisages to become a superpower in the coming years for it to happen it becomes a necessity to further ensure that it continues the process of amalgamating international

standards in its system. Much has been done and much has to be done.

#### **Acknowledgment**

We would like to acknowledge the various authors (sources of whom have been mentioned in the references) for throwing more light on Indian Transmission System. Their information has been a prime source for this research paper and is the primary reason this paper could see the light of the day.

#### **References**

- [1] SR Narsimhan, V Pandey. Facilitating Open access without compromising grid security 2010. <https://posoco.in/documents/published-papers/>
- [2] Ravinder, A Talegaonkar. Developing Power Exchange(s) in India: Issues and Challenges, 2008. <https://posoco.in/documents/published-papers/>
- [3] SK Soonee. Realizing a Collective Vision through non-cooperation 2005, <https://posoco.in/documents/published-papers/>
- [4] B Bhushan. Proceeding towards Power Pools; Framework for Electricity Trading in India-A Power grid's Scheme, 1997, <https://posoco.in/documents/published-papers/>