

# Improving the Tractive Performance with Four-Wheel Drive (4WD) System

Neeraj Budhraj, Amit Pal

Department of Mechanical Engineering, Delhi Technological University, New Delhi-110042, India

## Article Info

Article history:

Received 24 January 2018

Received in revised form

10 March 2018

Accepted 20 May 2018

Available online 15 June 2018

**Keywords-** Four-wheel drive; differential; propeller shaft; tractive effort; traction

## Abstract

This paper gives a brief study of the components, operating modes, merits and demerits of a four-wheel drive system over two-wheel drive system, and a case study of Mahindra Scorpio S11 is done for tractive effort by 4WD and 2WD (front wheel drive). The results for Mahindra Scorpio S11 showed that the tractive effort by 4WD system increases as the gear ratio decreases, i.e., highest for reverse gear (14362.96 Nm) with gear ratio 3.28:1, 1<sup>st</sup> gear (13000.00 Nm) with gear ratio 2.97:1, 2<sup>nd</sup> gear (9066.67 Nm) with gear ratio 2.07:1 whereas lowest for 6<sup>th</sup> gear (2451.85 Nm) with gear ratio 0.56:1. Similar results for tractive efforts by 2WD (front wheel drive) system can be depicted, i.e., highest tractive effort for reverse gear (7674.07 Nm), 1<sup>st</sup> gear (6940.74 Nm), 2<sup>nd</sup> gear (4837.04 Nm) whereas lowest for 6<sup>th</sup> gear (1311.11 Nm). As observed, the tractive effort by a 4WD system is comparatively higher than a 2WD (front wheel drive) vehicle. Thus, this results into reduced wheel slippage tendency, better climbing capability in hilly areas and better driving control over the vehicle on the low frictional surfaces such as wet/snowy surfaces. Whereas additional components in 4-wheel drive system adds on weight; increases cost, maintenance, repair, noise and vibrations; and makes the construction comparatively more complex.

## 1. Introduction

In order to improve efficiency and to reduce pollution from vehicles various significant efforts have been carried out in research and development of new age vehicles [1]. A wide range of improvement is done in engine, i.e. engine cylinder; piston head; valve and spark plug mounting; and valve timing. Also, some auxiliary arrangements such as turbocharging and supercharging have been performed to improve efficiency and to control pollution emissions. All these practices have improved efficiency of the engine and reduced pollution emissions significantly. But still there is further loss of power from engine to wheels. As the research further extended, it was found that the transmission loss of power can be reduced upto a certain extent which will directly contribute to improved efficiency, thus resulting in reduced emissions [2].

Till 1980s, the engines were placed at front of the vehicle with the rear axle as the driving axle due to cost and better stability point of view. These vehicles have simple construction and no torque steer since the front axle is not connected with power transmission. This gives increased traction as during acceleration vehicle weight is transferred backwards whereas more components of the transmission increases the weight, cost and reduces interior space [3-4]. As the vehicle is pushed, thus low grip surface (wet road, ice, snow, etc) handling becomes difficult. This arrangement has also oversteering tendency.

Most of the modern vehicles come with front axle as driving axle and the engine is placed at front of the vehicle. In this way, driving axle is nearer to the engine which results in less components of the transmission reducing low chassis weight, increasing interior spacing and thus lighter construction and lesser mechanical inertia in the power train gives greater fuel economy. Pulling action of the engine proves to be safer as it reduces skidding tendency providing better road adhesion and understeering characteristics helps in better controlling of the vehicle [4]. On the other hand, the front axle is burdened with both steering and power transmission making the whole arrangement complicated. Ordinary universal joints will not work, thus two constant velocity joints have to be used which wear out much faster. Also, decreased tractive effort while going up and heavier steering on levelled roads makes this arrangement less suited for racing cars [5]. Torque steer and increased turning circle are other problems faced in this arrangement.

Another arrangement was also tried with rear axle as driving axle and the engine placed at the rear of the vehicle. This arrangement gives better traction through improved road adhesion on levelled roads as well as on slopes. Front axle is used only for steering thus resulting in simplified construction, reduced chassis weight, better visibility

**\*Corresponding Author,**

**E-mail-address:** neeraj\_budhraj@yahoo.com;

amitpal@dce.ac.in

**All rights reserved:** <http://www.ijari.org>

and better design from streamline point of view. Compact silencer system and exhaust pipe contribute in carrying away noise and heat from the passengers [5]. While increased weight at rear of the vehicle makes it unstable at high speeds and cause oversteering conditions. Positioning of the engine at the rear require complicated linkage to operate engine, clutch and transmission; and reduces cooling efficiency making relatively more difficult to access, servicing and repair. Lastly, fuel tank placed at the front results in fatal condition during a collision.

There is one more arrangement which is called four-wheel drive (4WD) system. In 4-wheel drive system, a two-speed transfer case (two driving axle) is designed mainly for low-speed, off-road driving. 4-wheel drive reduces wheel slippage tendency and provides better driving control over the vehicle [6-9]. 4-wheel drive system consists of a transfer box called auxiliary box which divides equal torque between the rear and front axles, normal universal joints on propeller shafts, special constant universal joints on the front axle to provide large angular movement during steering. The vehicle is capable of driving over the rough roads and snowy roads as well as over the roads with changing surface characteristics due to changing weather conditions [10].

## 2. Additional Components of 4-Wheel Drive system

Figure 1 depicts diagram of 4-wheel drive system showing various components required. The main components of 4-wheel drive system are discussed-

### 2.1 Differential

A 4-wheel drive vehicle has two differentials, one located on the front axle and one on the rear axle. The torque from the driveshaft or transmission is transmitted to the wheels using differentials. Also during taking a turn, the inside and the outside wheels of the vehicle rotate at varying speed and in similar fashion the front and the rear wheels of the vehicle rotate at the varying speed. Thus, differentials are used to enable this speed difference between the inside and outside wheels as well as front and rear wheels.

### 2.2 Transfer case

Splitting of the engine power between the front and rear axles on a 4-wheel drive vehicle is done by the transfer case. It interlocks the front axle drive shaft with the rear axle drive shaft in order to force the wheels to spin at the same speed. Transfer case enables the driver for better driving condition for cross-country operation and smoother drive in high or low gear as required.

### 2.3 Four-Wheel Drive System

A block diagram of 4-wheel drive system is shown in figure 3 with all essential components. The power of the engine is transmitted through the gearbox to the transfer case where the power splits between the front and rear axles on a 4-wheel drive vehicle. Then through the front and rear axle the power is transferred onto the differential. The torque (turning force) applied to the differential is transferred along two drive

shafts, which are joined to each wheel, causing them to rotate in the direction of travel.

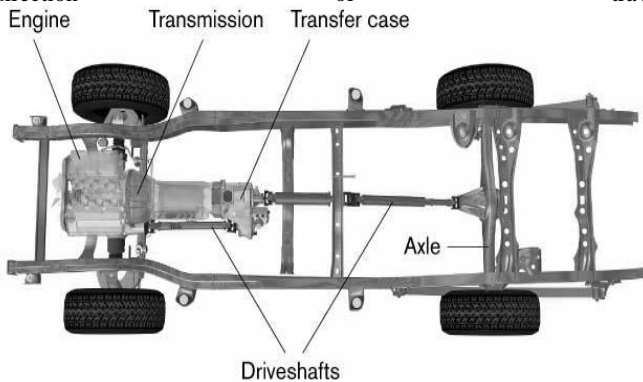

Fig. 1: Key Components of four-wheel drive [12]

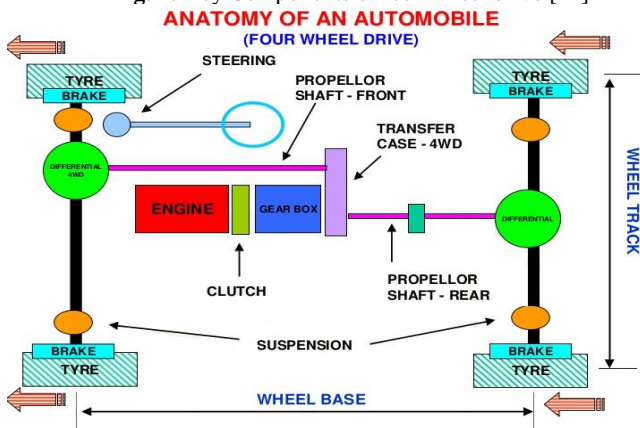

Fig. 1: Schematic of four-wheel drive system

3. Basic Considerations of Four-Wheel Drive [11]

3.1 Transmission wind-up

When a positive torque occurs in one of the axle and a negative torque in the other, such a condition is known as transmission wind-up. Transmission wind-up causes unusual torsional deflection or twisting resulting into permanent distortion.

3.2 Torque distribution

The tractive force to propel the vehicle is translated from the driving torque applied to the wheels depends upon the coefficient of friction between the road and tyres, and the vertical load. Thus, acceptable condition to achieve equal distribution of driving torque is only with equally distribution of weight between the rear and front axles.

3.3 Tractive Effort

The total force which is available at the contact between the road and the drive wheel tyres is termed as Tractive Effort. How tractive effort is related to engine power is as follows:-

$$\text{Engine Torque, } T_e = \frac{60000 P_e}{2\pi N} \text{ Nm} \dots\dots\dots(1)$$

$$\text{Torque at Drive wheels } T_w = (g.r \times a.r \times t.r)\eta_t T_e = G\eta_t T_e \dots\dots\dots(2)$$

$$\text{Tractive effort, } F = \frac{T_w}{r} = \frac{G\eta_t T_e}{r} \text{ N} \dots\dots\dots(3)$$

$$\text{Overall transmission efficiency, } \eta_t = \frac{P_{out}}{P_{in}} \times 100 \dots\dots\dots(4)$$

$$\text{Overall gear ratio, } G = g.r \times a.r \times t.r \dots\dots\dots(5)$$

- where,
- $P_e$  → engine power (kW)
  - $T_e$  → mean engine torque (Nm)
  - $P_{out}$  → output power (kW)
  - $P_{in}$  → input power (kW)
  - $g.r$  → gearbox ratio
  - $a.r$  → axle ratio
  - $t.r$  → transfer case ratio
  - $G$  → overall gear ratio
  - $r$  → radius of tyre (m)

$N$  → r.p.m. of crankshaft

3.4 Merits of 4-Wheel Drive

3.4.1. Cornering stability

Load reduction on each tire of the vehicle due to equally transmission of power by all four tires instead of only two effectively utilizes the cornering force of the tire and thus provides excellent cornering stability.

3.4.2. Straight-line stability

Each tire is having additional grip with road which increases the road adhesion resulting with better stability from external turbulence (or cross-winds), thus giving better straight-line stability to the vehicle.

3.4.3 Starting performance and acceleration

4-wheel drive vehicles having nearly double the tire gripping as compared to two-wheel drive vehicles perform better during starting, sudden acceleration or braking and do not allow spinning of the tires of the vehicle even mounted with a high torque engine. Thus, improving the starting performance and acceleration of the vehicle.

3.4.4. Performance during Hill-climbing

The best advantage of 4-wheel drive is during climbing hill or climbing a slope. Four-wheel drive approximately doubles the climbing capability of the vehicle thus making the vehicle safer on hilly areas.

3.4.5. Driving on low friction snowy/rough roads

In 4-wheel drive, equal power transmissions by all four wheels will approximately double the power transmitted by two-wheel drive. Thus, 4-wheel drive vehicles perform extremely well on roads with low coefficients of friction like wet, snowy roads. This is achieved by greater power provided by all four wheels. Basically, the front and rear wheels help each other as a result the performance increases significantly.

3.4.6. Better turning stability

The driving becomes more secure with 4-wheel drive vehicle due to better steering precision and better steering response. The turning radius of the vehicle reduces allowing the vehicle for easier and quicker corner parking and also easier maneuvering.

3.5 Demerits of 4-Wheel Drive

3.5.1. Weight is increased

As the number of parts in the power transmission line increases, the weight of the vehicle increases and thus, reduces the loading capacity.

3.5.2. Cost is increased

Increase in number of parts in the power transmission system with complex construction of transmission line significantly increases the cost of the vehicle while the repair and maintenance cost also increases simultaneously.

3.5.3. Construction is complex

Additional components such as transfer case, propeller shaft, differential, etc., required for the transmission of power from the engine to the wheels make the construction more complex.

3.5.4. Enhanced vibrations and noise

Increase in number of moving parts (transfer, propeller shaft, etc.) in the transmission line impart more vibrations and noise; and this increased vibrations and noise results in more wear and tear of the vehicle.

4. Case Study

Specifications of Mahindra Scorpio [13]

Model	=	S11
Engine	=	mHawk
Number of cylinders	=	4
Displacement	=	2179cc
Maximum engine output	=	103 kW @ 3750rpm
Maximum torque	=	320 Nm @ 1500-2800rpm
Number of gears	=	6 (Manual)
Tyre	=	P235/65 R17 (Radial Tubeless)
Wheel Base	=	2.68m

Turning radius = 5.4m (2WD) & 5.65m (4WD)

**Table 1:** Table for Gear ratio

Gear	1 <sup>st</sup>	2 <sup>nd</sup>	3 <sup>rd</sup>	4 <sup>th</sup>	5 <sup>th</sup>	6 <sup>th</sup>	reverse
Ratio	2.97	2.07	1.43	1.00	0.84	0.56	3.28

Axle ratio, a,r = 3.47 (FWD) & 3.55 (RWD)

Transfer ratio, t,r = 1.83 (4WD) & 1.00 (2WD)

From equation (1) & (4):-

$$P_{out} = \frac{2\pi N}{60000} T_e = \frac{2\pi \times 2800}{60000} \times 320 = 93.8 \text{ kW}$$

$$\eta_t = \frac{P_{out}}{P_{in}} \times 100 = \frac{93.8}{103} \times 100 = 91\%$$

**Table 2:** Torque at drive wheels and tractive effort by 4WD vehicle

S. No.	Gear	Gear ratio, g,r	Overall gear ratio, G	Torque, T <sub>w</sub> (in Nm)	Tractive Effort, F (in N)
1.	1 <sup>st</sup>	2.97	19.29	5616.0	13000.00
2.	2 <sup>nd</sup>	2.07	13.45	3916.8	9066.67
3.	3 <sup>rd</sup>	1.43	9.29	2704.0	6259.26
4.	4 <sup>th</sup>	1.00	6.50	1891.2	4377.78
5.	5 <sup>th</sup>	0.84	5.46	1590.4	3681.48
6.	6 <sup>th</sup>	0.56	3.64	1059.2	2451.85
7.	reverse	3.28	21.31	6204.8	14362.96

**Table 3:** Torque at drive wheels and tractive effort by 2WD (front wheel drive) vehicle

S. No.	Gear	Gear ratio, g,r	Overall gear ratio, G	Torque, T <sub>w</sub> (in Nm)	Tractive Effort, F (in N)
1.	1 <sup>st</sup>	2.97	10.30	2998.4	6940.74
2.	2 <sup>nd</sup>	2.07	7.18	2089.6	4837.04
3.	3 <sup>rd</sup>	1.43	4.96	1443.2	3340.74
4.	4 <sup>th</sup>	1.00	3.47	1011.2	2340.74
5.	5 <sup>th</sup>	0.84	2.91	848.0	1962.96
6.	6 <sup>th</sup>	0.56	1.94	566.4	1311.11
7.	reverse	3.28	11.38	3315.2	7674.07

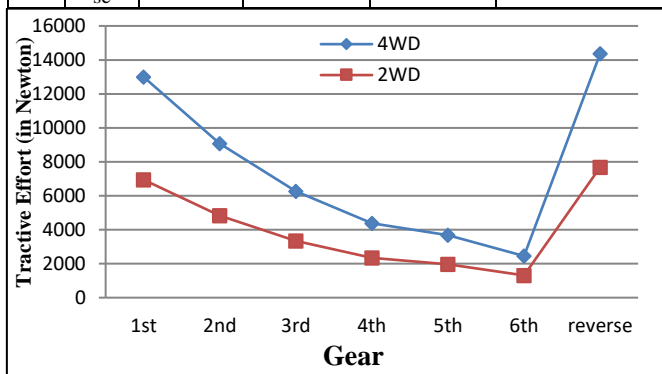

**Fig. 1:** Gear vs Tractive Effort (in Newton) of 4WD and 2WD

From the table 2, it is clear that the tractive effort by a four wheel drive vehicle increases as the gear ratio decreases, i.e., highest for reverse gear (14362.96 Nm), 1<sup>st</sup> gear (13000.00 Nm), 2<sup>nd</sup> gear (9066.67 Nm) whereas lowest for 6<sup>th</sup> gear (2451.85 Nm).

From Table 3, the similar results for tractive efforts by a two wheel drive (front wheel drive) vehicle can be observed, i.e., highest tractive effort for reverse gear (7674.07 Nm), 1<sup>st</sup> gear (6940.74 Nm), 2<sup>nd</sup> gear (4837.04 Nm) whereas lowest for 6<sup>th</sup> gear (1311.11 Nm).

But as observed from graph 1, the tractive effort by a 4-wheel drive is comparatively higher than a two wheel drive (front wheel drive) vehicle. This is due to the fact that a 4-wheel drive system requires transfer case (with transfer case ratio 1.83), which interlocks the front axle drive shaft with the rear axle drive shaft in order to split the power between front and rear axle wheels. In this way, better climbing capability on hilly areas and reduces slipping tendency of the vehicle.

## 5. Conclusions

This paper gives a brief study of 4-wheel drive system on various merits of 4-wheel drive system over two-wheel drive system. The results showed that the tractive effort by a 4-wheel drive vehicle increases as the gear ratio decreases, i.e., highest for reverse gear (14362.96 Nm) with gear ratio 3.28:1, 1<sup>st</sup> gear (13000.00 Nm) with gear ratio 2.97:1, 2<sup>nd</sup> gear (9066.67 Nm) with gear ratio 2.07:1 whereas lowest for 6<sup>th</sup> gear (2451.85 Nm) with gear ratio 0.56:1. Similar results for tractive efforts by a two wheel drive (front wheel drive) vehicle can be observed, i.e., highest tractive effort for reverse gear (7674.07 Nm), 1<sup>st</sup> gear (6940.74 Nm), 2<sup>nd</sup> gear (4837.04 Nm) whereas lowest for 6<sup>th</sup> gear (1311.11 Nm). But as observed, the tractive effort by a 4-wheel drive is comparatively higher than a two wheel drive (front wheel drive) vehicle.

Thus, it is concluded from the study that a 4-wheel drive system reduces wheel slippage tendency, gives better climbing capability on hilly areas and provides better driving control over the vehicle on the low frictional surfaces such as wet road, snowy road, mud and sand. Whereas additional components in four-wheel drive system adds on weight; increases cost, maintenance, repair and noise; and makes the construction more complex. But still the merits of 4-wheel drive system overcome the demerits upto a great extent.

## References

- [1]. CH Yu, CY Tseng, CM Chang. Study on Power Train of Two Axles Four Wheel Drive Electric Vehicle, Energy Procedia 14, 2012, 1528-1535.
- [2]. HB Das, SA Evangelou, SJ Dhinagar. An objective analysis of drivability for two wheeler powertrain with control oriented dynamic model, IFAC-Papers OnLine 48-15,2015, 292-299.
- [3]. K Matsun, R Nitta, K Inoue, K Ichikawa, Y Hiwataishi. Development of a New All-Wheel Drive Control System, Seoul 2000 FISITA World Automotive Congress, 6, 2000.
- [4]. P Russell and Osborn Taehyun Shim, Independent control of all-wheel-drive torque distribution, Vehicle System Dynamics, 44 (7), 2006, 529-546.
- [5]. Kirpal Singh, Automobile Engineering, 1, 12<sup>th</sup> edition 2011, 3-11.
- [6]. Smyth T and King M, Driver-Vehicle Interactions in 4WDs: A Theoretical Review, Australasian Road Safety Research, Policing Education Conference, 2006.
- [7]. W Zhifua, ZYangb, LI Chaopenga, F Jun. Research on Straight Line Stability Control Strategy of Four Wheel Drive Vehicle Based on the Sliding Mode Variable Structure Control and Optimization Algorithm, Energy Procedia 104, 2016, 342-347.
- [8]. G Li, W Hong, D Zhang, C Zong. Research on Control Strategy of Two Independent Rear Wheels Drive Electric Vehicle, International Conference on Applied Physics and Industrial Engineering, Physics Procedia 24, 2012, 87-93.
- [9]. B Gasbaoui, A Nasri. A novel 4WD electric vehicle control strategy based on direct torque control space vector modulation technique, Journal of Intelligent Control and Automation, 3 (3), 2012, 236-242.
- [10]. Abdelfatah Nasri, Brahim Gasbaoui and Ben Mohammed Fayssal, Sliding Mode Control for Four Wheels Electric Vehicle Drive, 9th International Conference Interdisciplinarity in Engineering, INTER-ENG 2015, 8-9 October 2015, Tirgu Mures, Romania, Procedia Technology 22, 2016, 518-526.
- [11]. MJ Nunney. Light and Heavy Vehicle Technology, 4<sup>th</sup> edition 2007, 432-433.
- [12]. [https://www.google.co.in/search?q=four+wheel+drive&rlz=1C1C HBF\\_enIN747IN747&source=lnms&tbnm=isch&sa=X&ved=0ah UKewiq74zelq7XAhVM2hoKHQRFBkoQ\\_AUICigB&biw=1366&bih=588#imgrc=3S91rFUtn4xjIM](https://www.google.co.in/search?q=four+wheel+drive&rlz=1C1C HBF_enIN747IN747&source=lnms&tbnm=isch&sa=X&ved=0ah UKewiq74zelq7XAhVM2hoKHQRFBkoQ_AUICigB&biw=1366&bih=588#imgrc=3S91rFUtn4xjIM)
- [13]. <http://www.mahindrascorpio.com/mahindra-scorpio-model.aspx>