

Design and Manufacturing of Honing Tool for Drilling Machine

Ashok Kumar Yadav ^a, Shatrughan Singh ^b, Uttam Ghosh ^b, Gaurav Gupta ^c

^a Department of Mechanical Engineering, Jamia Millia Islamia University, Delhi, India

^b Department of Mechanical Engineering, IILM Academy of Higher Learning, Greater Noida, U.P, India

^c Department of Mechanical Engineering, Amity University, Noida, U.P. India

Article Info

Article history:

Received 2 January 2014

Received in revised form

10 January 2014

Accepted 20 January 2014

Available online 1 February 2014

Keywords

Honing,
Higher Accuracy,
Gun Barrel Machining,
Dial Gauge,
Catia Software

Abstract

Honing is an abrasive machining process that is the "best kept secret" at many leading gun barrel producers, whether the end product is a fine sniper rifle, a police service pistol or an aircraft cannon. Simply put, honing produces a more accurate barrel a better overall product for lower cost. The Aim of the research is to design and manufacturing a honing tool for a drilling machine that can give require surface finish and dimensional accuracy as given by a honing machine and since we know that honing machine are very costly and every manufacturer cannot afford it on the other hand drilling machine are cheap as compare to honing machine and are available even in small workshops so our basic aim to reduce the cost of surface finish is fulfilled and we are succeed in getting the same surface finish and dimensional accuracy obtain by a honing machine. The contents of this report include design, manufacturing and working of honing tool and their study as well. It is well known that a good honing machine is very costly and all manufacturers cannot afford it. We have also seen that hand honing is resorted to by road side repairers and their cylinders lack in the requirements of circularity/cylindricity& smoothness. The design is simple in the sense that any manufacture having a drilling machine and simple manufacturing facilities can manufacture on his own and achieve the necessary technical requirements of smoothness of surface as well as requirements of close tolerance on circularity and cylindricity. We use our tool in a drilling machine, because these are very cheap as compared to honing machines and are also available in every mechanical workshop. So our main aim is to reduce the cost of honing and at the same time achieve the desired accuracy as given by the honing machine i. e, in the range of 0.005 microns.

1. Introduction

We all know that honing tool are used with grinding sticks (Abrasive bonded sticks) and is a very important machining process in a precision component manufacturing workshop. In a cylinder-piston system, cylinder holes are required to have near circularity & cylindricity as well as smoothness of surface. This requirement is especially important in Hydraulic/Pneumatic and Gasoline engines etc. It was hence considered worthwhile to design a Honing tool, which is simple in design and can be used in a drilling

machine (a machine tool available commonly with all manufacturers) and also should result in fulfilling the technical requirement of finish and close dimension control in the section of the hole. So we have made our own design for tool and this is manufactured by the machinist. We will use this tool in drilling machine for hole finishing operations in internal cylinders. We aim to achieve the accuracy up to 0.005mm.

1.1 Honing principle

The principle of operation of honing consists in having rotary motion as well as its translatory motion using a heavy feed rate. It requires a allowance of 0.2 mm in the hole size so that the bore can be finished fast using initially medium grit honing stick followed

Corresponding Author,

E-mail address: ashokme015@gmail.com

All rights reserved: <http://www.ijari.org>

by fine grit honing sticks. The process requires continuously flushing out of the used abrasive grain from the honing sticks so as to avoid the abrasive grains get embedded in between the grain & result in glazing the honed surface.

1.2 Honing Machine

The process of honing can be done on many general purpose machines also, such as lathes and drilling machines. In production work where the honing is to be done on a large scale, such machines will fail to give satisfactory and economical results. In such cases, the use of regular honing machines will give the desired results. These honing machines are made in various types and sizes. The most common classification of these is as follows:-

1.3 Horizontal Honing Machine

These machines are mostly used for honing comparatively longer jobs, such as gun barrels. All such machines carry a horizontal spindle, on which is mounted the honing tool.

1.4 Vertical Honing Machine

These machines hold the work as well as the tool in vertical positions. They are available in both single and multiple spindle types.



Fig: 1. Horizontal Honing Machine



Fig: 2. Vertical Honing Machine

2. Design of Honing Tool

Designing of the honing tool is done by CatiaV6 software

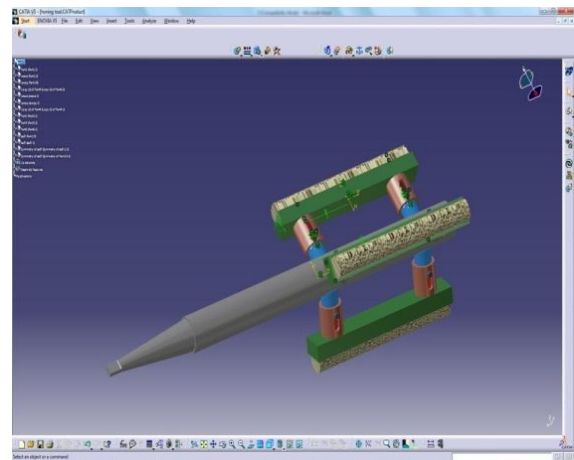

Fig: 3. Designed model of honing tool

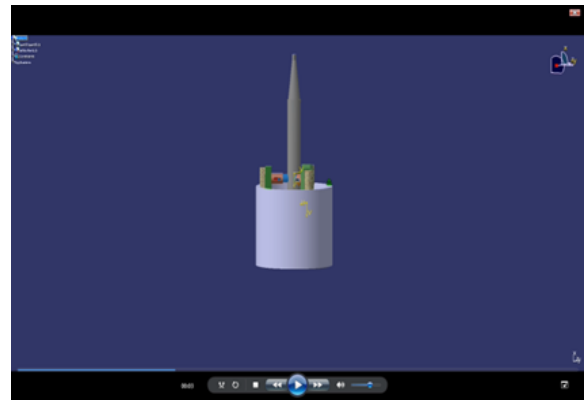

Fig: 4. view of designed model of honing tool

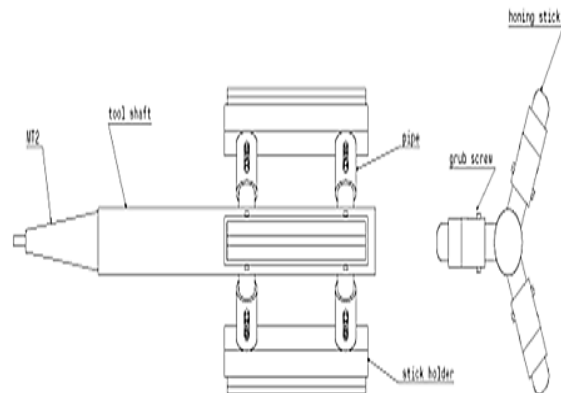

Fig: 5. Honing tool for a drilling machine

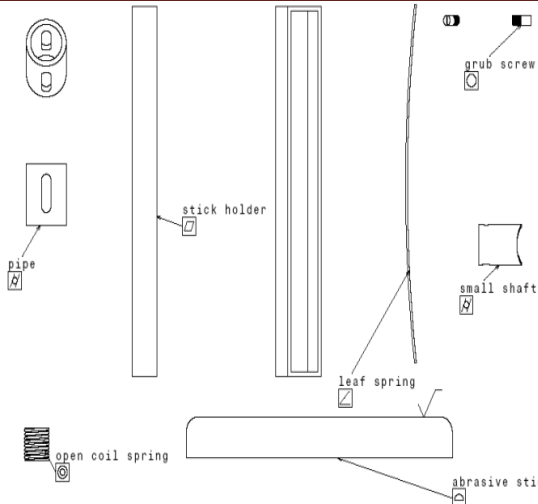

Fig: 6. Different parts of a honing tool

Table: 1. Parts List

SNO	DESCRIPTION	MATERIAL	QTY
1	MANDREL	EN 8	1
2	PIN	EN 8	6
3	PIPE	EN 8	6
4	HELICAL SPRING	STEEL	6
5	STICK HOLDER	EN 8	3
6	LEAF SPRING	STEEL	3
7	GRUB SCREW	STAINLESS STEEL	12
8	HONING STICK	SILICON CARBIDE	3

2.1 Abrasive honing sticks

Honing stick is bonded abrasive stone made in the form of a stick. Silicon Carbide is used for stick material.



Fig: 7. Abrasive honing sticks

2.2 Drilling Machine

Drilling machine is one of the simplest, moderate and accurate machine tool used in production shop and too room. It consists of a spindle which imparts rotary motion to the drilling tool, a mechanism for feeding the tool into the work, a table on which the work rests and a frame

3. Manufacturing of Tool

3.1 Machines used

Lathe, Milling, Drilling, Grinding, Welding M/C are used for the machining purposes.

3.2 Steps Involved In Manufacturing of Tool

Centring, Facing, Turning, Plane Milling, Face Milling, Drilling, Tapping, MIG, Welding, Grinding, Etc.

3.3 Cylinder Block

We have performed honing operation on cylinder block

- Cylinder Material : Alloy steel

3.4 Dimensions

- Diameter 119 mm
- Length 150 mm

3.5 Instrument used for measurement

- Profilometer
- Bore Gauge
- Height Gauge

3.6 Profilometer

Profilometer is a measuring instrument used to measure a surface's profile, in order to quantify its roughness. Vertical resolution is usually in the nanometre level, though lateral resolution is usually poorer.

3.7 Contact Profilometers

A diamond stylus is moved vertically in contact with a sample and then moved laterally across the sample for a specified distance and specified contact force. A profile meter can measure small surface variations in vertical stylus displacement as a function of position



Fig: 8. Dial Bore Gauges

A dial bore gauge is an instrument used for the measurement of the internal diameter of cylinders. A dial bore gauge is a special purpose dial indicator for checking bores, and has such they are pretty expensive.

3.8 Reading Technique

To achieve a reading, the gauge is first zeroed. This is done by measuring across the gauge with an outside mike set to the specified bore size and rotating the dial face until 0 aligns with the needle. A typical diagram of Dial Bore Gauge is as shown in fig:-



Fig: 9. Dial Bore Gauges

Reference

- [1] Mehrabi, M.G. and Ulsoy, A.G., 1997, State-of-the-Art in Reconfigurable Machining Systems, ERC/RMS Technical Report, University of Michigan, Ann Arbor, Michigan.
- [2] Koren, Y., Heisel, U., Jovane, F., Moriwaki, T., Pritschow, G., Ulsoy, G., and Van Brussel, H., 1999, Reconfigurable Manufacturing Systems, Annals of the CIRP, 48/2, pp. 527–540.
- [3] Bollinger, J. et al., 1998, Visionary Manufacturing Challenges for 2020, National Research Council Report, National Academy Press, Washington, D.C.
- [4] Koren, Y., Kota, S., 1999, Reconfigurable Machine Tools, U.S. Patent 5,943,750
- [5] Landers, R.G., 2000, A New Paradigm in Machine Tools: Reconfigurable Machine Tools, Japan–USA Symposium on Flexible Automation, Ann Arbor, Michigan, July 23–26.
- [6] Genin, V.B. and Kozlov, A.I., 1990, New Modules Offer Enhanced Flexibility for Automatic Lines, Soviet Engineering Research, 61(2), pp. 14–17
- [7] Rogers, G.G. and Bottaci, L., 1997, Modular Production Systems: a New Manufacturing Paradigm, Journal of Intelligent Manufacturing, 8, pp. 147–156.
- [8] Garro, O. and Martin, P., 1993, Towards New Architectures of Machine Tools, International Journal of Production Research, 31(10), pp. 2403–2414.
- [9] Zatarain, M., Lejardi, E., and Egana, F., 1998, Modular Synthesis of Machine Tools, Annals of the CIRP, Vol. 47/1, pp. 333–336.
- [10] Moon, Y–M., Kota, S., A Methodology for Automated Design of Reconfigurable Machine Tools, Proceedings of the 32nd CIRP International Seminar on Manufacturing Systems, Leuven, Belgium, 1999, 297–303

4. Conclusions

Honing is a very accurate machining method. Honing produces a more accurate barrel a better overall product for lower cost. The Aim of the research is to design and manufacturing a honing tool for a drilling machine that can give require surface finish and dimensional accuracy as given by a honing machine and since we know that honing machine are very costly and every manufacturer cannot afford it on the other hand drilling machine are cheap as compare to honing machine and are available even in small workshops so our basic aim to reduce the cost of surface finish is fulfilled and we are succeed in getting the same surface finish and dimensional accuracy obtain by a honing machine. The contents of this report include design, manufacturing and working of honing tool and their study as well. 0.005 microns.