

Speed Control of Induction Motor Using Fuzzy Logic Approach

Kamini Devi ^{a*}, Rameshwar Singh ^a, Shailendra Gautam ^b, Deepak Nagaria ^c

^a Department of Electrical Engineering, Nagagi Institute of Technology and Management Gwalior, Madhya Pradesh, India

^b Department of Electrical Engineering, TIT Bhopal, Madhya Pradesh, India

^c Department of Electrical Engineering, Bundelkhand Institute Of Engineering & Technology, Jhansi, India

Article Info

Article history:

Received 2 January 2015

Received in revised form

10 January 2015

Accepted 20 January 2015

Available online 31 January 2015

Keywords

Fuzzy logic controller,
V/F controller, Induction
Motor,
Designing of FLC,
Simulation in Mat- Lab

Abstract

This paper presents a rule-based fuzzy logic controller applied to a scalar closed loop Volts/Hz induction motor (IM) control with slip regulation and its simulation results. The IM is model in terms of d-q windings, with synchronous frame associated with the frequency ω_s of the stator excitation. The results obtained in the simulation are interesting, considering the presence of strong non-linearity in the IM model. A fuzzy logic control for a speed control of Induction motor the simulation developed by using Fuzzy MATLAB Toolbox and SIMULINK. The fuzzy logic controller is also introduced to the system for keeping the motor speed to be constant when the load varies. Because of the low maintenance and robustness induction motors have many applications in the industries.

1. Introduction

The Fuzzy Logic Toolbox draws upon these capabilities to provide a powerful tool for fuzzy system design, analysis, and simulation. This technical brief describes the use of the Fuzzy Logic Toolbox to solve a typical control design problem. Fuzzy logic can make control engineering easier for many types of tasks. It can also add control where it was previously impractical, as applications such as fuzzy-controlled washing machines have shown. However, fuzzy control need not be a dramatic departure from conventional control techniques such as proportional integral derivative (PID) feedback systems. As this technical brief demonstrates, fuzzy logic can be used to simplify the scheduling of two different controllers.

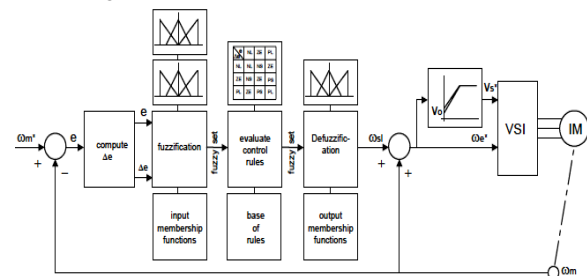

Fig: 1. Basic Block Diagram of Speed Control of Induction Motor Using FLC

2. Fuzzy Logic Controller (FLC)

The simulation developed by using Fuzzy MATLAB Toolbox for SIMULINK and fuzzy logic. MATLAB Fuzzy logic Toolbox is used to design fuzzy logic controller. Basically, the Fuzzy Logic controller consists of four basic components: fuzzification, a knowledge base, inference engine, and a defuzzification interface. The addition of fuzziness to data in fuzzy logic is called the fuzzification.

Corresponding Author,

E-mail address: sun.kamini@gmail.com

All rights reserved: <http://www.ijari.org>

Fuzzy linguistic description are formal representation of system made through fuzzy IF-THEN rules. They encoded knowledge about a system in statements of the form-

IF (a set of conditions) are satisfied then (a set of consequents) can be inferred. [2] In many situations, for a system whose output is fuzzy, it is easier to take a crisp decision if the output is represented as a single scalar quantity. This conversion of a fuzzy set to single crisp value is called defuzzification. [3]

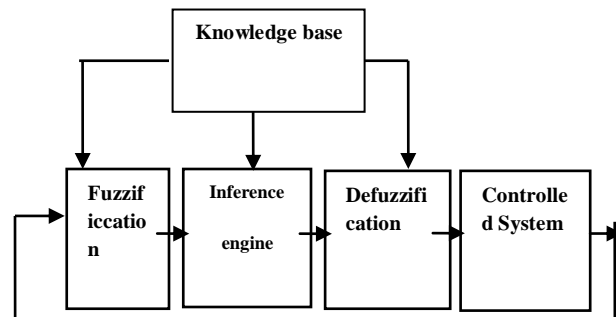

Fig: 2. Basic Configuration of Fuzzy Logic Controller

3. V/F Control

A discussion of induction motor control theory is beyond the scope of this document. We will mention here only the salient points of VF control. The *base speed* of the induction motor is directly proportional to the supply frequency and the number of poles of the motor. Since the number of poles is fixed by design, the best way to vary the speed of the induction motor is by varying the supply frequency. The torque developed by the induction motor is directly proportional to the ratio of the applied voltage and the frequency of supply. By varying the voltage and the frequency, but keeping their ratio constant, the torque developed can be kept constant throughout the speed range [4]

$$\Phi_{ag} = \text{constant} = \frac{E_{ag}}{f} = \frac{V}{f} \quad (1)$$

Where: V =applied voltage, f = supply frequency, E_{ag} = counter e.m.f [5]

Figure3. Shows the typical torque-speed characteristics of the induction motor, supplied directly from the main supply. Figure4.shows the torque-speed characteristics of the induction motor with V/F control. Other than the variation in speed, the torque-speed characteristics of the V/F control reveal the following:

- At base speed, the voltage and frequency reach the rated values. We can drive the motor beyond the base speed by increasing the frequency further. However, the applied voltage cannot be increased beyond the rated voltage. Therefore, only the frequency can be increased, which results in the reduction of torque. Above the base speed, the factors governing torque become complex.[4]
- The acceleration and deceleration of the motor can be controlled by controlling the change of the supply frequency to the motor with respect to time. [4]

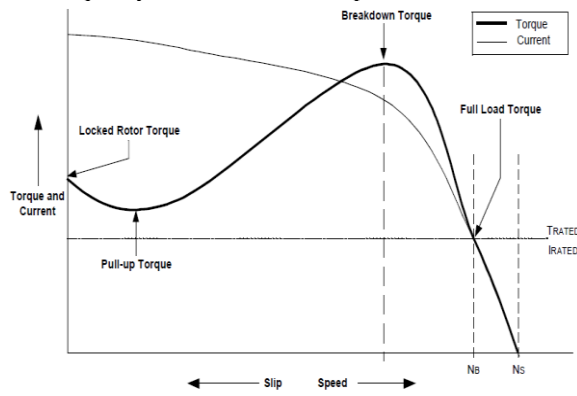

Fig: 3. Torque-Speed Characteristics of Induction Motor

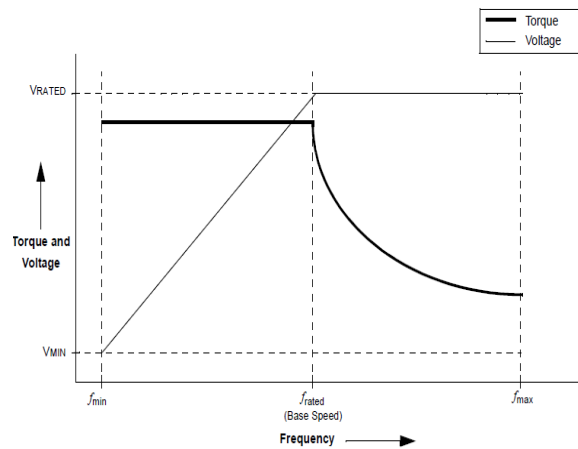

Fig: 4. Torque-Speed Characteristics of Induction Motor VF Control

4. Induction Motor

In the control of any power electronics drive system (say a motor), to start with a mathematical model of the plant is required. This mathematical model is required further to design any type of controller to control the process of the plant. The induction motor model is established using a rotating (d, q) field reference (without saturation) concept [6].

The power circuit of the 3- ϕ induction motor is shown in the Fig. 5. The equivalent circuit used for obtaining the mathematical model of the induction motor is shown in the Fig. 6. An induction motor model is then used to predict the voltage required to drive the flux and torque to the demanded values within a fixed time period. This calculated voltage is then synthesized using the space vector modulation. [6]

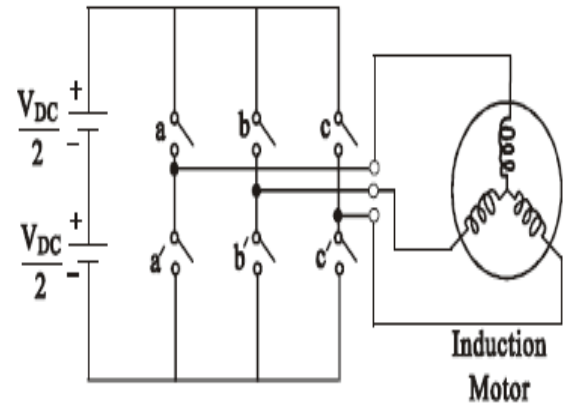

Fig: 5. Power Circuit Connection Diagram for the IM

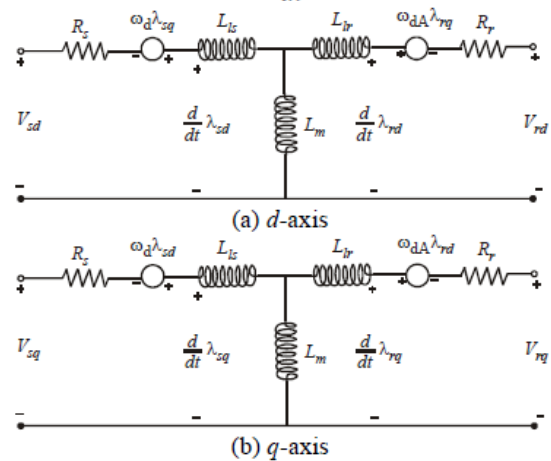

Fig.6. Equivalent Circuit of Induction Motor in d-q Frame

5. Designing of Fuzzy Logic Controller

Table1: Rules of Speed Control of Induction Motor Using FLC

de/e	Negative Large	Negative Medium	Negative Small	Zero	Positive Small	Positive Medium	Positive Large
Negative Large	NL	NL	NLM	NM	NMS	NS	ZE
Negative Medium	NL	NLM	NM	NMS	NS	ZE	PS
Negative Small	NLM	NM	NMS	NS	ZE	PS	PSM

Negative Large	NM	NMS	NS	ZE	PS	PSM	PM
Negative Large	NMS	NS	ZE	PS	PSM	PM	PML
Negative Large	NS	ZE	PS	PSM	PM	PML	PL
Negative Large	ZE	PS	PSM	PM	PML	PL	PL

5.1 Membership Function Plots Of Input Variable “Error”, Input Variable “Change Of Error” And Output Variable “Change of Control”

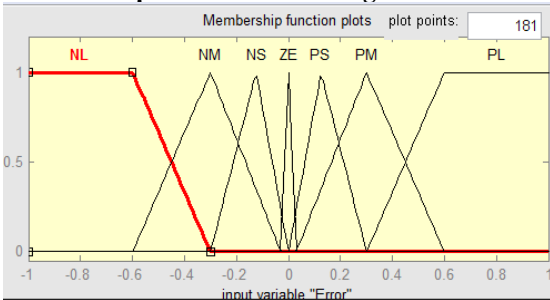

Fig: 7. Membership Function of “Input Error”

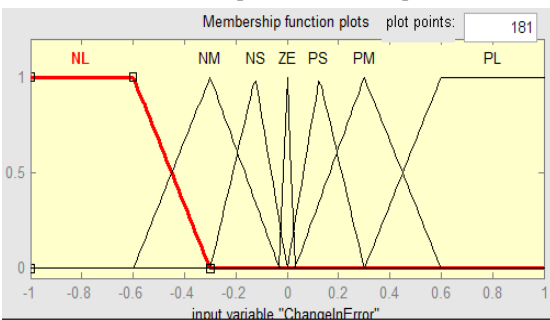

Fig: 8. Membership Function of “Input Change of Error”

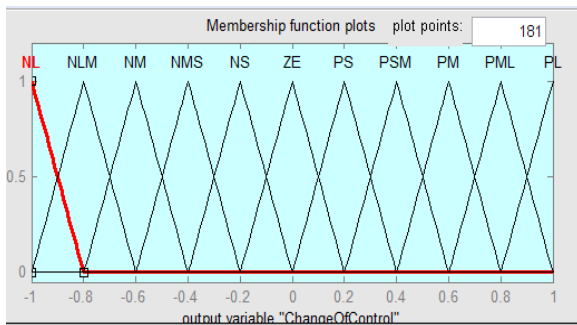

Fig: 9. Membership Function of “Output Change of Control”

5.2 Surface Viewer of Rules

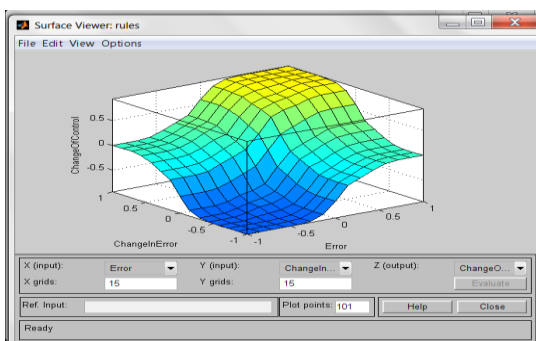

Fig: 10. Surface Viewer of FLC rules

6. Simulation Result

6.1 Implementation of speed control of induction motor using fuzzy logic

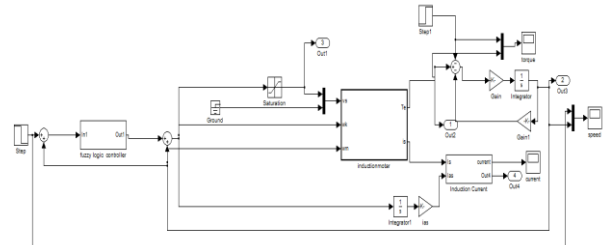

Fig.11.Circuit Diagram of Speed Control of Induction Motor Using FLC in Simulink

6.2 Result of speed, Torque and Current Characteristics of Induction Motor

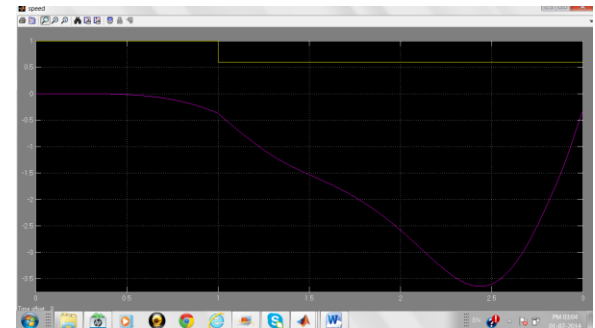

Fig12: Plot Speed v/s Time Characteristics

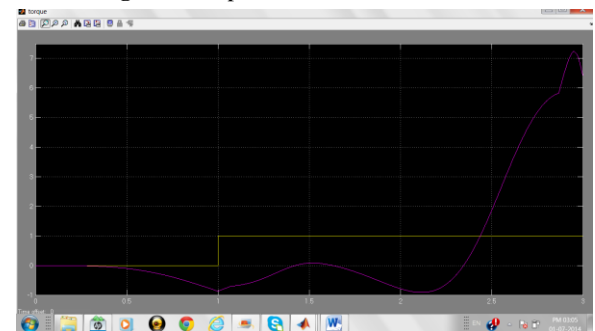

Fig13: Plot Torque v/s Time Characteristics

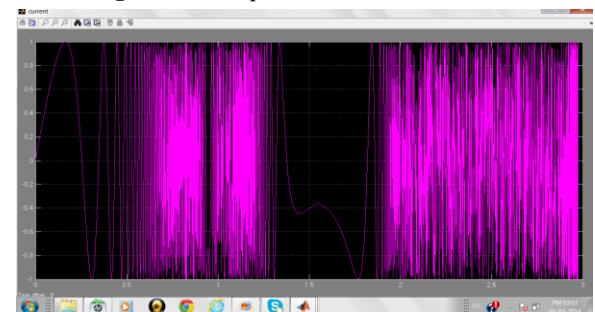

Fig14: Plot Current v/s Time Characteristics

7. Conclusion

An estimation of fuzzy logic techniques applied to the control of induction motor was presented. The fuzzy logic approach is feasible and can be an interesting alternative to conventional control, even when the system model is known

References

- [1] A J. L. fonso, J. Fonseca, J. S. Martins, C. A. Couto, Fuzzy logic techniques applied to the control of a three-phase induction motor, Industrial Electronics, ISIE '97, Proceedings of the IEEE International Symposium on, 3 Guimaraes, Portugal, 1997, 1179-1184
- [2] M. S. M. Aras, E. C. S. Hoo, M. H. b. Hairi, S. N. B. S. Salim, I. A. b. W. A. Razak, Comparison of Fuzzy Control Rules using MATLAB Toolbox and Simulink for DC Induction Motor-Speed Control, International Conference of Soft Computing and Pattern Recognition, 2009
- [3] S. Rajasekaran, G. A. Vijaylakshmi Pai, Neural Networks, fuzzy logic, and genetic algorithms synthesis and applications, Prentice Hall India, Eastern Economy Edition, 2005
- [4] R. Parekh, VF Control of 3-Phase Induction Motors Using PIC16F7X7 Microcontrollers, Microchip Technology Inc. ANN889
- [5] R. Maloth, Speed Control of Induction Motor Using Fuzzy Logic Controller, National Conference on Electrical Sciences, 2012
- [6] Yu Zhang, Z. Jiang, X. Yu, Indirect Field-Oriented Control of Induction Machines Based on Synergetic Control Theory, Proc. of the IEEE Int. Conf. on Power and Energy Society General Meeting Conversion and Delivery of Electrical Energy in the 21st Century-2008, 20-24, 1 – 7, 2008
- [7] M. N. Uddin, T. S. Radwan, M. A. Rahman Performances of Fuzzy-Logic-Based Indirect Vector Control for Induction Motor Drive, IEEE Transactions on Industry Applications, 38(5), 2002, 1219- 1225
- [8] <http://www.mathworks.com/> (The official site for MATLAB&SIMULINK as well as Fuzzy Logic Toolbox)
- [9] H. Sugimoto, S. Tamai, Secondary resistance identification of an Induction Motor Applied Model reference Adaptive Systems and its Characteristics, IEEE Trans. on Ind. Appl., IA-23(1), 1987, 296- 303
- [10] C. Y. Won, B. K. Bose, An induction Motor servo Systems with Improved Sliding Mode Control, in Proc. IEEE IECON'92, 60-66
- [11] J. C. Hung, Practical Industrial Control techniques, in Proc. IEEE IECON'94, 7-14