

Total Cross Flow (TCF) Hydrostatic Journal Bearing: A Review

Paras Kumar

Department of Mechanical Engineering, Delhi Technological University, Delhi, India

Article Info

Article history:

Received 8 January 2015

Received in revised form

15 January 2015

Accepted 22 January 2015

Available online 31 January 2015

Keywords

Total Cross Flow Bearing,

Lubricant,

Circumferential Grooved Land

Abstract

Hydrostatic bearings are used extensively in machine tool application due to their high load carrying capacity, no stick-slip, very low friction at low or zero speed, high stiffness and damping characteristics. If the features of circumferential grooved land and external return flow system incorporate in the conventional Hydrostatic bearing design, it turns to a new bearing design that is Total Cross Flow (TCF design = Conventional design + Circumferential grooved land + External return flow system) hydrostatic bearing. This new externally pressurized bearing overcomes most of the side effect of conventional journal Bearing (CJB) like undesirable hydrodynamic effect associated with the oil turbulence and critical rise in temperature. TCF bearing are also consider suitable for high speed application along with good damping and stiffness characteristic with low temperature rise. Reduce drag power loss, fast temperature stabilization, and stability at high rotational speed are the other meritorious properties of TCF bearing. A detailed summery of literature review on TCF bearing covering different performance characteristics like total power loss, recesses pressure, squeeze load, temperature distribution, fluid flow, damping and stiffness coefficients are discussed and tabulated. It is observed through literature review that most of the studies on TCF journal bearing are experimental except analytical study made by Kumar et al. [7] and it is emphasized to carry out analytical and modeling work to validate or to analyze different features and aspects related to bearing configuration, lubricant properties, and type of restrictors etc.

1. Introduction

Externally pressurized journal bearing have been known as early as 1865. Currently, they are commonly used in various technologies because of the advantage of complete freedom from wear and excellent characteristics with respect to fluid film stiffness, low friction, good vibration damping characteristics and smooth relative motion even at low rotational speeds. A conventional hydrostatic bearing unlike a hydrodynamic bearing has its sliding surfaces continuously and completely separated by a pressurized oil film under static and dynamic conditions within the design range. The most commonly used hydrostatic journal bearing configuration is the multirecess Hydrostatic Journal Bearing as shown in Fig.-1. This type of configuration contains a number of recess or pocket disposed equally around the circumferential direction. Lubricant is introduced to each recess through separate restrictors.

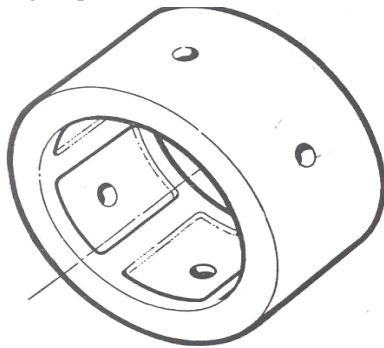

Fig. 1. Conventional Hydrostatic Journal Bearing [Ref.-1]

Corresponding Author,

E-mail address: paraskum007@rediffmail.com

All rights reserved: <http://www.ijari.org>

It is also pointed out that the main problem with conventional design of hydrostatic bearing is the undesirable hydrodynamic effect associated with the oil turbulence in the pocket under critical dynamic condition. This is because the friction losses due to shearing of oil both in pressurized pocket and under the lands become excessive. At high speed, oil temperature rises within the bearing can eventually result in deterioration of the oil film between the sliding surface and the bearing failure due to metal to metal contact.

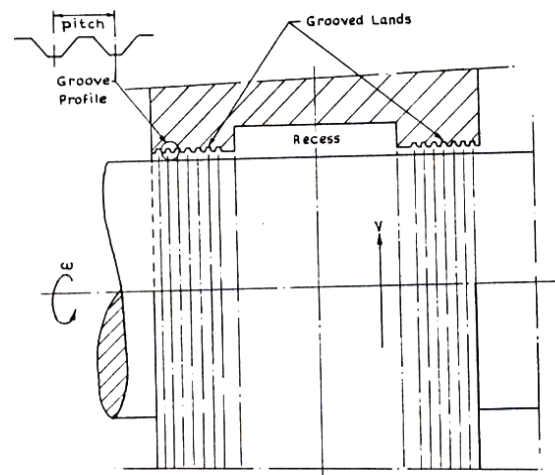

Fig. 2. Circumferential Grooved Lands TCF Hydrostatic Journal Bearing [Ref.-2]

Research and design engineers have optimized and developed different design and most effective solution to enhance the performance of hydrostatic bearings so far is

International Conference of Advance Research and Innovation (ICARI-2015)

the total cross flow design concept. The total cross flow bearing design is the modified design of conventional journal bearing design by providing groove on circumferential land and external flow return system as shown in Fig.-2.

The investigations [2-7] include the detailed discussion about the TCF design and concept. Mohsin, M.E. and Sharratt, A. [2] carried out an experimental investigation into the behaviour of pad with groove lands and tells that under speed application, a wide grooved land offer many advantages over a flat land with enough width to give the same hydrostatic impedance. Mohsin, M.E. and Sharratt, A. [3] critically investigated into the behaviour of TCF hydrostatic journal bearing when run at clearance peripheral speed of up to 60 m/sec. A comparison was also made with conventionally design feature similar to TCF but without their entire design feature. As a result, the studies confirmed the important merits of the TCF hydrostatic bearing especially at high speeds when other types of bearing fail to offer favourable characteristics. Mohsin, M.E. [4] analyzed the Total Cross-Flow (TCF) hydrostatic bearing for high and ultra-high speed application offers a number of

meritorious properties. It has concluded that under speed condition, the TCF bearing substantially reduces the friction coefficient and drag power losses of the bearing and ensuring fast temperature stabilization at acceptable levels. It also reduce the total minimum power consumed and practically eliminates the effect of pocket pressure differential and the possibility of land drying-up, thus reducing the possibility of bearing cavitation. It reduces the hydrodynamic effects to negligible values, nearly eliminating all the corresponding disadvantages of the hybrid action such as bearing-whirl and cavitation. The TCF bearing behaves almost as a pure hydrostatic bearing and hence, when pressurized by an incompressible fluid, is unconditionally stable. Mohsin, M.E., Seif, A.A., and Shaheen, M [5] studied the effect of grooved land on the squeeze load characteristics and on the damping capacity of bearings. A comparison was also given between the damping capacity of bearings with grooved land and that of bearings with equivalent flat lands to give the same pressure flow characteristics. It was observed that the bearing with grooved lands have 12 times more damping as compared to bearing with flat land for same axial hydraulic resistance.

Table: 1. Details of Literature Review for Total Cross Flow Hydrostatic Journal Bearing in Tabular Form

Ref. No.	Type of Paper/ analysis (Theoretical/ Experimental)	Bearing Geometric Parameter		Methodology	Performance Parameter (Measured/ Evaluated/ Computed)	
		Type of				Groove geometry
		Bearing/groove Design	Lubricant			
1	Experimental	Hydrostatic Pad	Newtonian	Trapezium Triangular	Experimental Test Rig.	Hydrostatic Impedance and Viscous Shear Drag
2		TCF Rigid Bearing				-
3	Theoretical	TCF Rigid Bearing	Newtonian	Solve mathematical Equation or expression	Experimental Test Rig	Power and temperature distribution, Total power
4						Squeeze load characteristic, Damping capacity
5	Experimental	TCF Rigid Bearing	Newtonian	Trapezoidal	Reynolds equation Using FEM approach	Test head drive torque, oil in and oil out temperature, oil flow rate, Bearing pad pressure.
6	Theoretical	TCF Rigid Bearing	Newtonian	Trapezoidal	Reynolds equation Using FEM approach	Maximum pressure, bearing flow, stiffness coefficient and threshold speed.

Abdolmaleki, M., Skorin, A., Wardle F.P and Wood A.E. [6] carried out the experimental comparison between the performance of TCF bearing and equivalent conventional bearing. Flat land hydrostatic bearing clearly demonstrate the advantages of the former in terms of much higher running speed capability with no penalty in temperature rise and shear power loss. Furthermore pocket pressure stability with respect to increase shaft speed for TCF journal bearing tested up to 1 million DN is over 4 times better than that for the equivalent conventional design tested up to 0.6 million DN with a similar temperature rise. Kumar et al. [7] described a theoretical study concerning the effect of circumferential grooved lands on the performance

of Total Cross Flow (TCF) multirecess hydrostatic/hybrid journal bearing system. The Reynolds equation and the equation of flow through the restrictor were solved using the Finite Element Method. Further, a comparative performance study has also been carried out between the conventional journal bearing (CJB) and total cross flow (TCF) for the same geometric and operating parameters. Results computed from the study indicates that from the view point of the fluid film stiffness, the TCF bearing at groove pitch () =1mm and groove angle () =1500 is likely to provide better performance in comparison to conventional hydrostatic journal bearings The result presented in this study also demonstrate that the performance of the TCF

 International Conference of Advance Research and Innovation (ICARI-2015)

bearing can be improved by proper selection of groove pitch and groove angle.

It is observed through literature review that most of the studies on TCF journal bearing are experimental except analytical study made by kumar et al. [7] and there is need to carry out more analytical work to validate or to analyze other bearing designs features. The comprehensive summary of literature review on TCF hydrostatic journal bearing is presented in Table-1. The table covers the different aspects like bearing geometric parameters, groove geometry, methodology used and performance parameters measured/evaluated/computed.

2. Conclusion

The Total Cross Flow Hydrostatic bearing is an externally pressurized bearing with design feature to overcome most of the side effects of conventional hydrostatic bearing. This is done by designing the bearing in exactly the same manner as the well known conventional

References

- [1] A. Harnoy, Bearing Design in Machinery: Engineering Tribology and Lubrication, CRC press, 2002
- [2] M. E. Mohsin, A. Sharratt, The behavior of hydrostatic pads with grooved lands, Tribology Int., 1981, 33-45
- [3] M. E. Mohsin, A. Sharratt, The behaviour of a total cross flow hydrostatic bearing, Proc. 22nd International MTDR Conference, Manchester, 1981, 13
- [4] M. E. Mohsin, A hydrostatic bearing for high speed application: The Total Cross Flow hydrostatic bearing, Tribology Int., 47-54, 1981
- [5] M. E. Mohsin, A. A. Seif, M. Shaheen, The dynamic behaviour of fluid bearing with grooved lands, Tribology Int., 1986, 133-140
- [6] M. Abdolmaleki, A. Skorin, F. P. Wardle, R. E. Wood, An experimental comparison between the performance of a total cross flow and an equivalent conventional design hydrostatic journal bearing, Tribology source, 1988, 445-454
- [7] P. Kumar, S. C. Jain, S. C. Sharma, A study on the performance of a TCF multirecess hydrostatic/hybrid journal bearing, International conference on Industrial Tribology-(ICIT), 2006

hydrostatic bearing. The novel feature of circumferential grooved land has added to the hydrostatic bearing to reduce the adverse effects of cavitation and turbulence in the bearing pocket and undesirable hydrodynamic action beneath the land. In general, the Total Cross Flow (TCF) Hydrostatic journal bearing for high speed applications offer substantially reduction in drag power losses, higher heat dissipation, uniform temperature distribution and quick temperature stabilization [2]. It also shows stability at higher rotational speed and eliminates the chances of bearing cavitations.

Most of the works carried out by researchers [2-6] are experimental in nature. So it is emphasized to carry out analytical or modelling work to validate or to analyze different features and aspects related to bearing configuration, lubricant properties, and type of restrictors etc., which are sometime not feasible experimentally due to lack of resources.